

MARTIN[®]
WHIRLWIND[™]
High-Frequency Turbine Vibrator

[Go to MARTIN[®] WHIRLWIND[™] High-Frequency Turbine Vibrator web page](#)



Operator's Manual
M3655

Important

MARTIN ENGINEERING HEREBY DISCLAIMS ANY LIABILITY FOR: DAMAGE DUE TO CONTAMINATION OF THE MATERIAL; USER'S FAILURE TO INSPECT, MAINTAIN AND TAKE REASONABLE CARE OF THE EQUIPMENT; INJURIES OR DAMAGE RESULTING FROM USE OR APPLICATION OF THIS PRODUCT CONTRARY TO INSTRUCTIONS AND SPECIFICATIONS CONTAINED HEREIN. MARTIN ENGINEERING'S LIABILITY SHALL BE LIMITED TO REPAIR OR REPLACEMENT OF EQUIPMENT SHOWN TO BE DEFECTIVE.

Observe all safety rules given herein along with owner and Government standards and regulations. Know and understand lockout/tagout procedures as defined by American National Standards Institute (ANSI) z244.1-1982, *American National Standard for Personnel Protection - Lockout/Tagout of Energy Sources - Minimum Safety Requirements* and Occupational Safety and Health Administration (OSHA) Federal Register, Part IV, 29 CFR Part 1910, *Control of Hazardous Energy Source (Lockout/Tagout); Final Rule*.

The following symbols may be used in this manual:



Danger: Immediate hazards that will result in severe personal injury or death.



Warning: Hazards or unsafe practices that could result in personal injury.



Caution: Hazards or unsafe practices that could result in product or property damages.



Important: Instructions that must be followed to ensure proper installation/operation of equipment.



Note: General statements to assist the reader.

Table of Contents

Section	Page
List of Figures and Tables	ii
Introduction	1
General	1
References	1
Safety	1
Installation and Start-up	2
Weekly Maintenance	4
Troubleshooting	4
Part Numbers	5

List of Figures

Figure	Title	Page
1	Locating Vibrators and Reinforcing Beams on Hoppers	2
2	Connecting Air Lines to Vibrator	3
3	MARTIN [®] WHIRLWIND [™] Turbine Vibrator Assembly, P/N 37628	5

List of Tables

Table	Title	Page
I	Recommended Pipe Size for Compressed Air Flow to 125 psi (8.62 bar)	4
II	Performance Chart and Part Numbers for 40 psi (2.67 bar)	6
IIa	Performance Chart and Part Numbers for 60 psi (4.14 bar)	6
IIb	Performance Chart and Part Numbers for 80 psi (5.52 bar)	6
III	Additional Part Numbers	6

Introduction

General

The MARTIN® WHIRLWIND™ High-Frequency Turbine Vibrator is unique in that the turbine rotor assembly is encapsulated in urethane and produces more power with less noise than any other high-force, high-frequency pneumatic turbine vibrator.

With an output of 10,000 lb-f (45 kN), the MARTIN® WHIRLWIND™ High-Frequency Turbine Vibrator doubles the force output of the most powerful competitive models. Units mount easily to cradle lug brackets or railcar wedge brackets and operate quietly to meet OSHA noise requirements.

References

The following documents are referenced in this manual:

- *The National Electrical Code (NEC) Handbook*, National Fire Protection Association, 1 Batterymarch Park, P.O. Box 9101, Quincy, MA., 02269-9101.
- American National Standards Institute (ANSI) z244.1-1982, *American National Standard for Personnel Protection - Lockout/Tagout of Energy Sources - Minimum Safety Requirements*, American National Standards Institute, Inc., 1430 Broadway, New York, NY 10018.
- Federal Register, Volume 54, Number 169, Part IV, 29 CFR Part 1910, *Control of Hazardous Energy Source (Lockout/Tagout); Final Rule*, Department of Labor, Occupational Safety and Health Administration (OSHA), 32nd Floor, Room 3244, 230 South Dearborn Street, Chicago, IL 60604.

Safety

All safety rules defined in the above documents and all owner/employer safety rules must be strictly followed when working on the vibrator.

Installation and Start-up

IMPORTANT

Read this entire section before beginning work.

WARNING

Before installing equipment, lock out/tag out energy source.

1. Turn off and lock out/tag out energy source according to American National Standards Institute (ANSI) z244.1-1982 and Federal Register, Volume 54, Number 169, Part IV, 29 CFR Part 1910.
2. Make sure mounting surface and vibrator are clean and free of debris.
3. See figure 1. Locate vibrator in lower 1/4 to 1/3 of structure slope length. If second vibrator is needed, mount 180 degrees from first vibrator and halfway up slope.

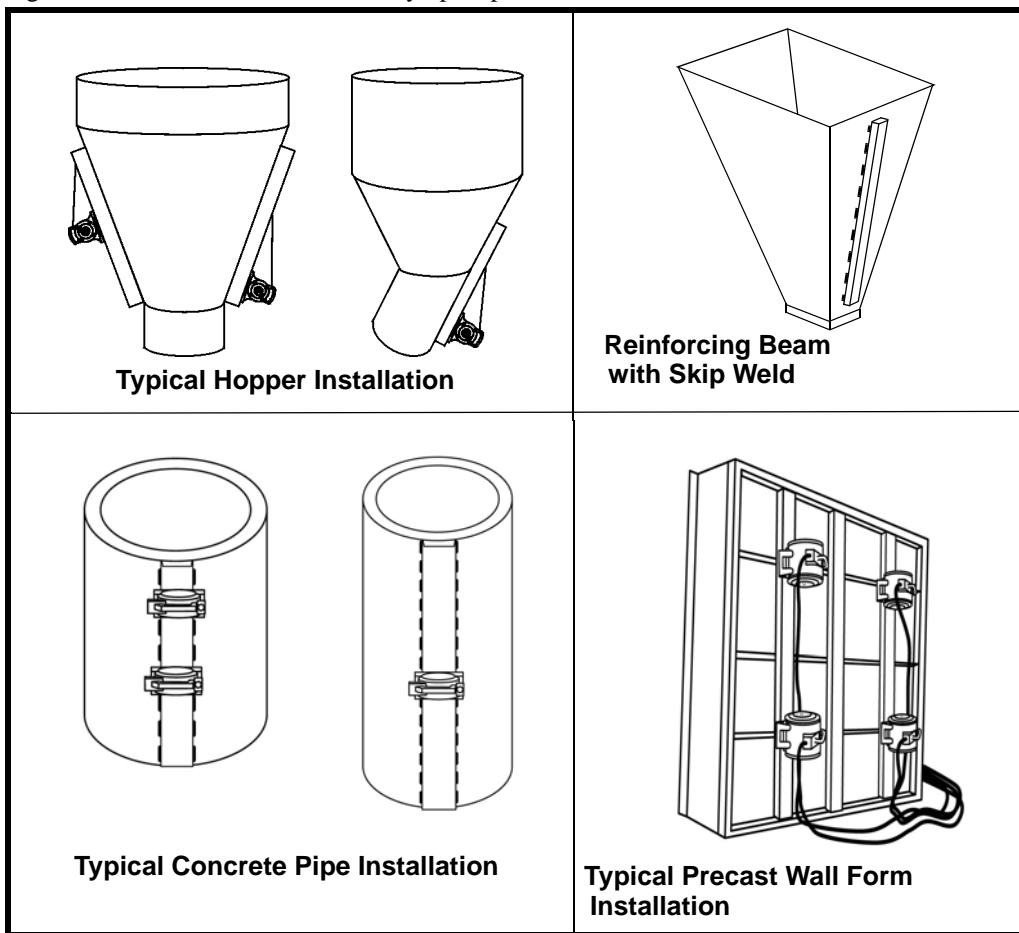

Figure 1. Locating Vibrators and Reinforcing Beams on Hoppers

CAUTION

If reinforcing beam is not skip welded, hopper may be damaged by operating vibrator.

4. If necessary, install reinforcing beam to strengthen chute wall (see figure 1). Skip weld beam in place: Weld 3 in. (76 mm) then skip 2 in. (51 mm). Repeat for entire perimeter of beam. Do not weld last 1 in. (25 mm) of either end of beam or any corner. Make sure beam extends at least 3/4 the length of structure from top to bottom.

5. Install mounting plate. Skip weld in place. (Mounting plate should be at least the size of vibrator base.)
6. Install vibrator onto mount using new cap screws, compression washers, and lock nuts. See table I for mounting bolt sizes and torque requirements.
7. Run a 3/4- to 1-in. (19- to 25-mm) I.D. air line (supplied by the customer) to the intake on the vibrator as follows. (See Table II for recommended pipe sizes.)
 - a. See figure 2. Connect air line to ball valve (A) and Filter/Regulator Kit (B). Need clean/dry air and pressure regulation.

NOTE

No lubrication. In-line oilers can damage bearing grease.

WARNING

Wire control box and solenoid in accordance with National Electrical Code Article 430. Have wiring installed by a qualified electrician only.

- b. If using, connect power to control box (C) and solenoid valve (D).
- c. Connect air to vibrator.

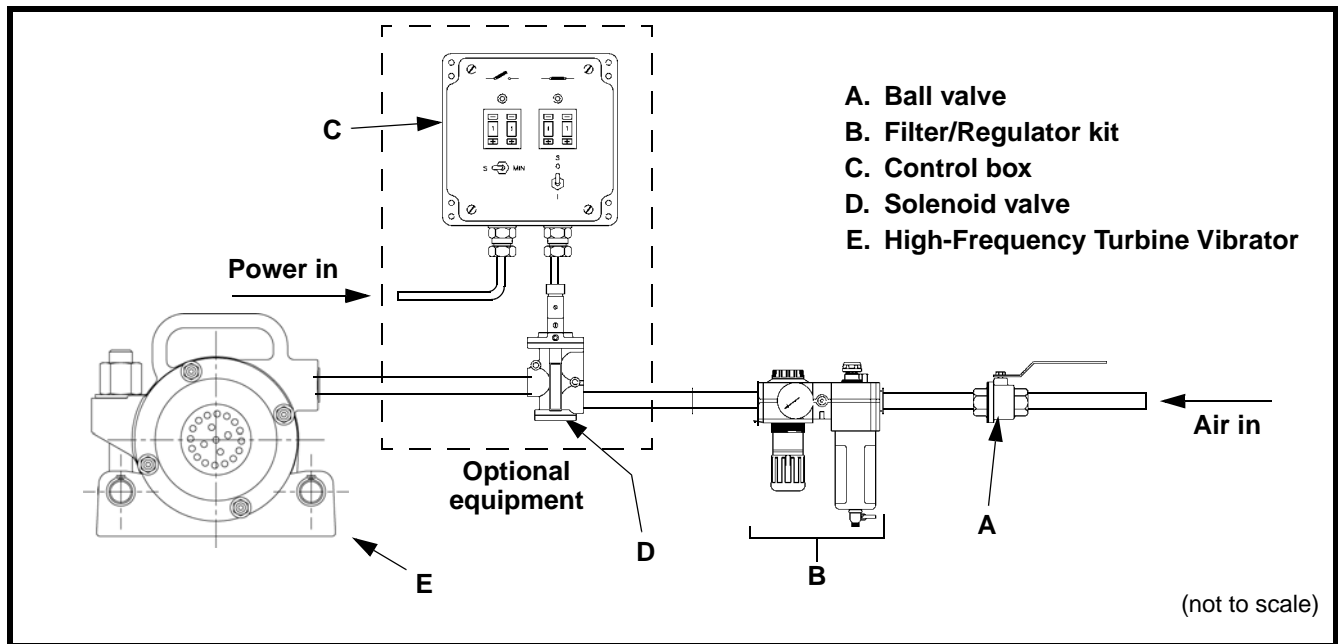

Figure 2. Connecting Air Lines to Vibrator

IMPORTANT

A new vibrator may require 3 minutes run time for break-in to come up to speed.

Table I. Recommended Pipe Size for Compressed Air Flow to 125 psi (8.62 bar)

Air Volume cfm (cls)	Pipe Length—ft (m) Nominal Pipe Diameter								
	25 (8)	50 (15)	75 (23)	100 (31)	150 (46)	200 (61)	300 (92)	500 (152)	1000 (305)
6 (2.8)	1/2	1/2	1/2	1/2	1/2	1/2	1/2	3/4	3/4
18 (8.5)	1/2	1/2	1/2	3/4	3/4	3/4	3/4	1	1
30 (14.2)	3/4	3/4	3/4	3/4	1	1	1	1-1/4	1-1/4
45 (21.3)	3/4	3/4	1	1	1	1	1-1/4	1-1/4	1-1/4
60 (28.3)	3/4	1	1	1	1-1/4	1-1/4	1-1/4	1-1/2	1-1/2
90 (42.5)	1	1	1-1/4	1-1/4	1-1/4	1-1/4	1-1/2	1-1/2	2
120 (56.6)	1	1-1/4	1-1/4	1-1/4	1-1/2	1-1/2	1-1/2	2	2
150 (70.8)	1-1/4	1-1/4	1-1/4	1-1/2	1-1/2	2	2	2	2-1/2
180 (85)	1-1/4	1-1/2	1-1/2	1-1/2	2	2	2	2-1/2	2-1/2
240 (113.3)	1-1/4	1-1/2	1-1/2	2	2	2	2-1/2	2-1/2	3
300 (141.6)	1-1/2	2	2	2	2	2-1/2	2-1/2	3	3
360 (170)	1-1/2	2	2	2	2-1/2	2-1/2	2-1/2	3	3

8. Start vibrator.
9. After 1 hour of operation, retighten mounting bolts while vibrator is operating.

Weekly Maintenance

1. Turn off and lock out/tag out energy source according to ANSI standards (see “Installation”).
2. Make sure fasteners are tight. Tighten if necessary.
3. Check filter for clean/dry air.

Troubleshooting

Symptom	Corrective Action
Vibrator does not come up to speed.	Allow 3 minutes break-in for new unit. Check air supply for cfm. Check air filter to insure there are no restrictions. Check mount for loose fit, broken welds.
Excess noise	Check mount for loose fit.

Part Numbers

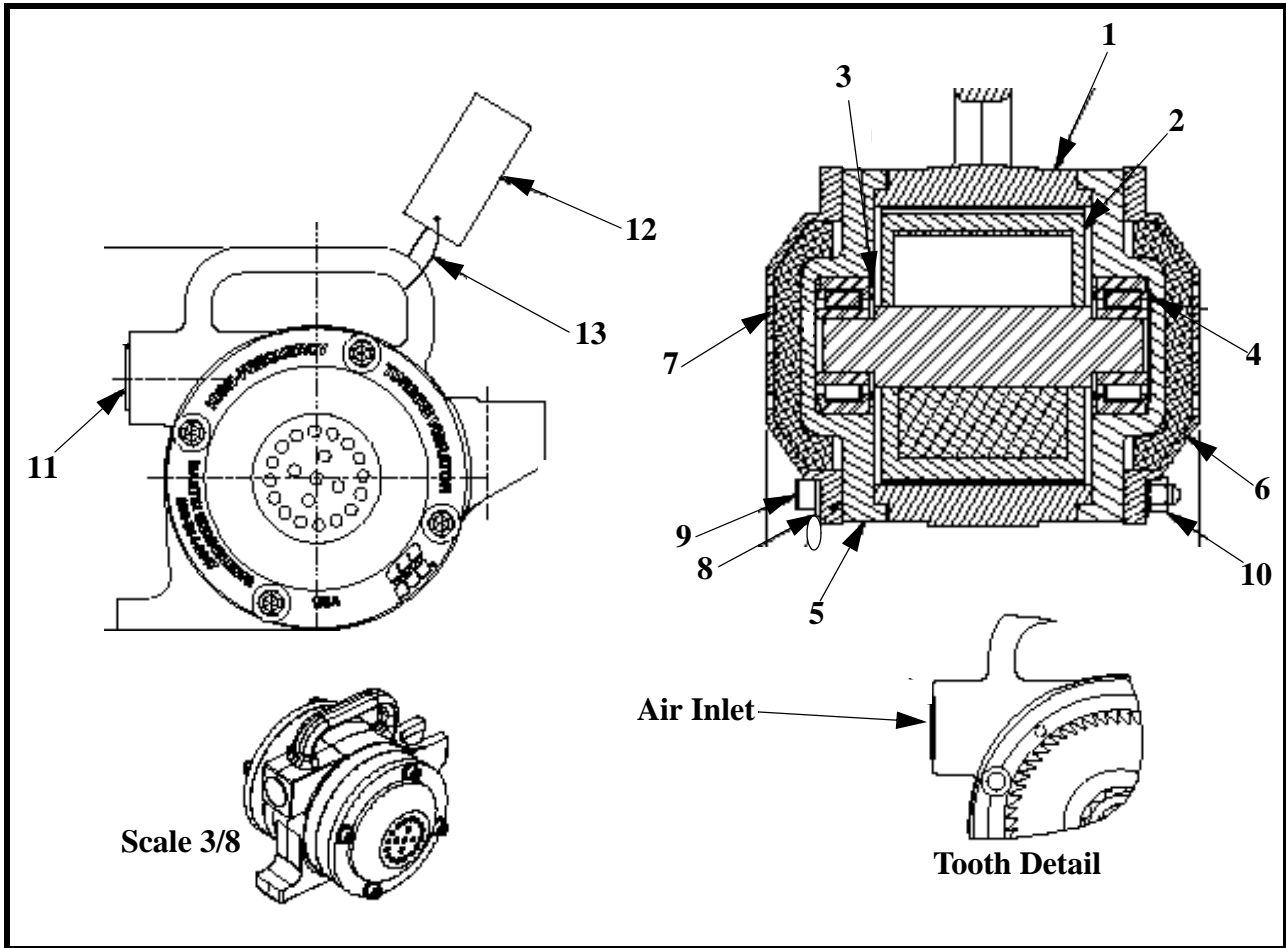

Item	Description	Part No.	Qty
1	Turbine Vibrator Case	37503-M	1
2	Rotor Assembly for Turbine Vibrator	37624	1
3	Metallic Bearing Seal (nilos ring)	37627	2
4	Bearing Cyl Roller 2.44 OD x .98 ID	37623	2
5	End Cap (machined)	37617	2
6	Foam Filter 3/4" x 4-1/2" Sq.	37634	2
7	Cap Cover	37619	2
8	Washer Compression 3/8	11747	8
9	Screw SHC 3/8 - 16NC x 6-1/2	37629	4
10	Nut Hex 3/8 - 16NC ZP	11770	4
11	Plug Plastic 1.00	36011	1
12	Tag OSHA Hearing Protection	34085	1
13	Tie Nylon Cable	30916	1
*14	Manual, Operator	M3655	1

*Not Shown

Figure 3. MARTIN® WHIRLWIND™ Turbine Vibrator Assembly, P/N 37628

Table II. Performance Chart and Part Numbers for 40 psi (2.67 bar)

Part Number	Model	Unbalance in-lb (cm-kg)	VPM	cfm (L/m)	Force lb (kg)	dbA
37628	WHIRLWIND™	4.2 (4.8)	6500	21 (595)	4415 (2003)	72

Table IIa. Performance Chart and Part Numbers for 60 psi (4.14 bar)

Part Number	Model	Unbalance in-lb (cm-kg)	VPM	cfm (L/m)	Force lb (kg)	dbA
37628	WHIRLWIND™	4.2 (4.8)	8400	25 (708)	7373 (3345)	74

Table IIb. Performance Chart and Part Numbers for 80 psi (5.52 bar)

Part Number	Model	Unbalance in-lb (cm-kg)	VPM	cfm (L/m)	Force lb (kg)	dbA
37628	WHIRLWIND™	4.2 (4.8)	10100	28 (793)	10660 (4836)	76

Table III. Additional Part Numbers

Part No.	Description
37628	Vibrator only
37628-C	Vibrator w/cradle lug bracket
37628-W	Vibrator w/wedge bracket
28732	Cradle lug bracket
29551	Wedge bracket
17214	3/4" Ball valve
37020	1" Ball valve
37630	Rotor/Bearing Repair Kit

Any product, process, or technology described here may be the subject of intellectual property rights reserved by Martin Engineering Company. Trademarks or service marks designated with the ® symbol are registered with the U.S. Patent and Trademark Office and may be proprietary in one or more countries or regions. Other trademarks and service marks belonging to Martin Engineering Company in the United States and/or other countries or regions may be designated with the “TM” and “SM” symbols. Brands, trademarks, and names of other parties, who may or may not be affiliated with, connected to, or endorsed by Martin Engineering Company, are identified wherever possible. Additional information regarding Martin Engineering Company’s intellectual property can be obtained at www.martin-eng.com/trademarks.



*We Make Your Bulk Materials Handling
Cleaner, Safer and More Productive
Through Personalized Performance.*



QUALITY MANAGEMENT SYSTEM
CERTIFIED BY DNV

==== **ISO 9001** ====

Form No. M3655-03/05
© 2003, 2005 MARTIN ENGINEERING COMPANY. All rights reserved.

One Martin Place
Neponset, IL 61345-9766 USA
800-544-2947 or 309-594-2384
FAX: 309-594-2432
www.martin-eng.com