

***martin***®

# **MARTIN® APRON SEAL™ Skirting System**

[Go to MARTIN® APRON SEAL™ Skirting System web page](#)

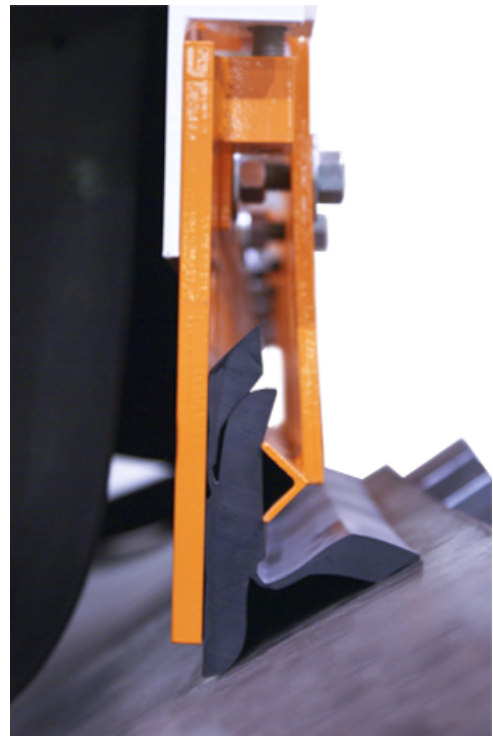
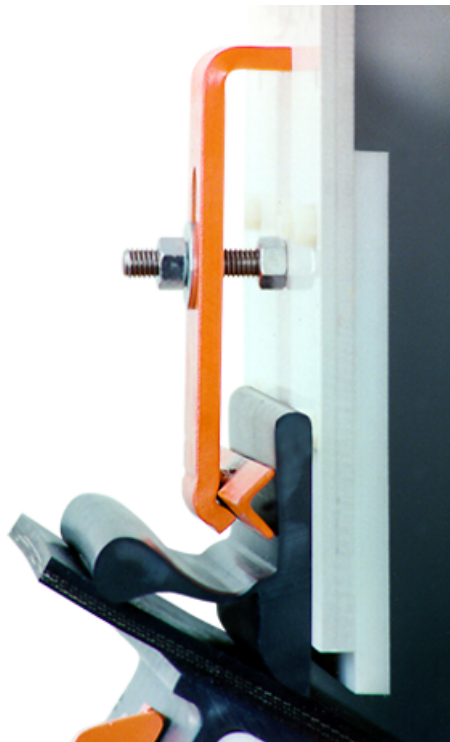

***Operator's Manual***  
***M3248***

# Important

MARTIN ENGINEERING HEREBY DISCLAIMS ANY LIABILITY FOR: DAMAGE DUE TO CONTAMINATION OF THE MATERIAL; USER'S FAILURE TO INSPECT, MAINTAIN AND TAKE REASONABLE CARE OF THE EQUIPMENT; INJURIES OR DAMAGE RESULTING FROM USE OR APPLICATION OF THIS PRODUCT CONTRARY TO INSTRUCTIONS AND SPECIFICATIONS CONTAINED HEREIN. MARTIN ENGINEERING'S LIABILITY SHALL BE LIMITED TO REPAIR OR REPLACEMENT OF EQUIPMENT SHOWN TO BE DEFECTIVE.

Observe all safety rules given herein along with owner and Government standards and regulations. Know and understand lockout/tagout procedures as defined by American National Standards Institute (ANSI) z244.1-1982, *American National Standard for Personnel Protection - Lockout/Tagout of Energy Sources - Minimum Safety Requirements* and Occupational Safety and Health Administration (OSHA) Federal Register, Part IV, 29 CFR Part 1910, *Control of Hazardous Energy Source (Lockout/Tagout); Final Rule*.

The following symbols may be used in this manual:



**Danger:** Immediate hazards that will result in severe personal injury or death.



**Warning:** Hazards or unsafe practices that could result in personal injury.



**Caution:** Hazards or unsafe practices that could result in product or property damages.



**Important:** Instructions that must be followed to ensure proper installation/operation of equipment.



**Note:** General statements to assist the reader.

# Table of Contents

---

Section	Page
List of Figures .....	ii
Introduction .....	1
General .....	1
MARTIN® APRON SEAL™ Skirting System materials .....	1
References .....	1
Safety .....	2
Materials required .....	2
Before Installing MARTIN® APRON SEAL™ Skirting System .....	3
Installing MARTIN® APRON SEAL™ Skirting System .....	4
After Installing MARTIN® APRON SEAL™ Skirting System .....	6
Monthly Maintenance .....	6
Part Numbers .....	7
Appendix A. MARTIN® APRON SEAL™ Skirting System Mounting Dimensions .....	A-1
Appendix B. MARTIN® APRON SEAL™ Selection Guide .....	B-1

## **List of Figures**

---

<b>Figure</b>	<b>Title</b>	<b>Page</b>
1	Locating Chute Wall and Wear Liner . . . . .	4
2	Installing MARTIN <sup>®</sup> APRON SEAL <sup>™</sup> Skirting . . . . .	4
3	MARTIN <sup>®</sup> APRON SEAL <sup>™</sup> Skirting System Assemblies . . . . .	8
4	Conveyor Products Warning Label, P/N 23395 . . . . .	9

# Introduction

## General

The MARTIN® APRON SEAL™ Skirting System is a self-adjusting conveyor belt skirting system that prevents spillage without requiring regular service to maintain an effective seal.

The MARTIN® APRON SEAL™ Skirting System is a 1-piece dual sealing system that combines the benefits of the primary and secondary seal in one seal. The primary seal prevents the majority of the material being loaded onto the conveyor belt from leaking past the chute walls. The secondary seal follows the flexing of the conveyor belt edge to trap material that has escaped from the primary seal. The double seal is a 1-piece dual sealing system in a dual-sided single elastomer.

The MARTIN® APRON SEAL™ Skirting System can be used with MARTIN® Angle Clamps or most existing clamps. See Appendix A for mounting dimensions. For a comparison of the different types of MARTIN® APRON SEAL™ Skirting, see the Selection Guide in Appendix B.

## MARTIN® APRON SEAL™ Skirting System materials

Materials and specifications for the MARTIN® APRON SEAL™ Skirting System are shown in Table I.

**Table I. MARTIN® APRON SEAL™ Skirting System Materials and Specifications**

Type	Material	Durometer (Shore A)	Service Temperature Range
1-Piece Dual	EPDM Rubber	70	-20 to 250°F -29 to 121°C
	EPDM Rubber (heavy-duty)	70	-20 to 250°F -29 to 121°C
1-Piece Double Seal	EPDM Rubber	70	-20 to 250°F -29 to 121°C

## References

The following documents are referenced in this manual:

- American National Standards Institute (ANSI) z244.1-1982, *American National Standard for Personnel Protection - Lockout/Tagout of Energy Sources - Minimum Safety Requirements*, American National Standards Institute, Inc., 1430 Broadway, New York, NY 10018.
- Federal Register, Volume 54, Number 169, Part IV, 29 CFR Part 1910, *Control of Hazardous Energy Source (Lockout/Tagout); Final Rule*, Department of Labor, Occupational Safety and Health Administration (OSHA), 32nd Floor, Room 3244, 230 South Dearborn Street, Chicago, IL 60604.

***Safety***

All safety rules defined in the above documents and all owner/employer safety rules must be strictly followed when working on this equipment.

***Material required***

In addition to standard hand tools, a knife and MARTIN® Angle Clamps or equivalent are required to install this equipment.

# Before Installing MARTIN<sup>®</sup> APRON SEAL<sup>™</sup> Skirting System

## IMPORTANT

The delivery service is responsible for damage occurring in transit. Martin Engineering CANNOT enter claims for damages. Contact your transportation agent for more information.

1. Inspect shipping container for damage. Report damage to delivery service immediately and fill out delivery service's claim form. Keep any damaged goods subject to examination.
2. Remove skirting system from shipping container. Equipment in container should include the following:
  - MARTIN<sup>®</sup> APRON SEAL<sup>™</sup> Skirting System.
  - Two Conveyor Products Warning Labels, P/N 23395.
3. If anything is missing, contact Martin Engineering or representative.



## WARNING

Before installing equipment, lock out/tag out energy source to conveyor and conveyor accessories.

4. Turn off and lock out/tag out energy source according to ANSI standards (see "References").

## WARNING

If equipment will be installed in an enclosed area, test gas level or dust content before using a cutting torch or welding. Using a cutting torch or welding in an area with gas or dust may cause an explosion.

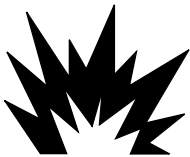

5. If using a cutting torch or welding, test atmosphere for gas level or dust content.

# Installing MARTIN<sup>®</sup> APRON SEAL<sup>™</sup> Skirting System

## IMPORTANT

For maximum skirting effectiveness, Martin Engineering recommends using MARTIN<sup>®</sup> DURT TAMER<sup>™</sup> Wear Liners with Skirting System (see “Part Numbers” for ordering information). Make sure chute wall and wear liners are straight and well-supported.

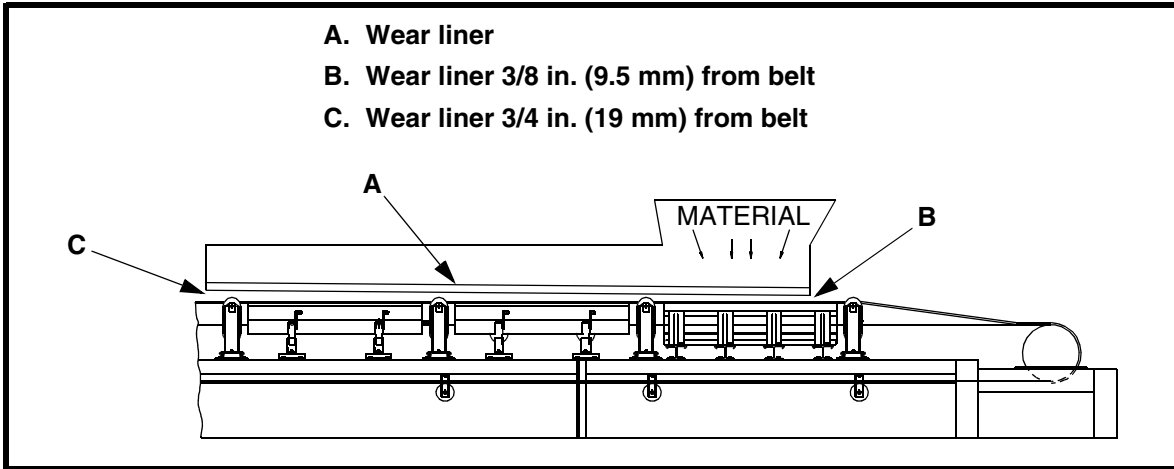

**Figure 1. Locating Chute Wall and Wear Liner**

1. Make sure wear liner (A, Figure 1) is 3/8 in. (9.5 mm) from belt at transfer point entry (B), and gradually increases to 3/4 in. (19.1 mm) at transfer point exit (C).

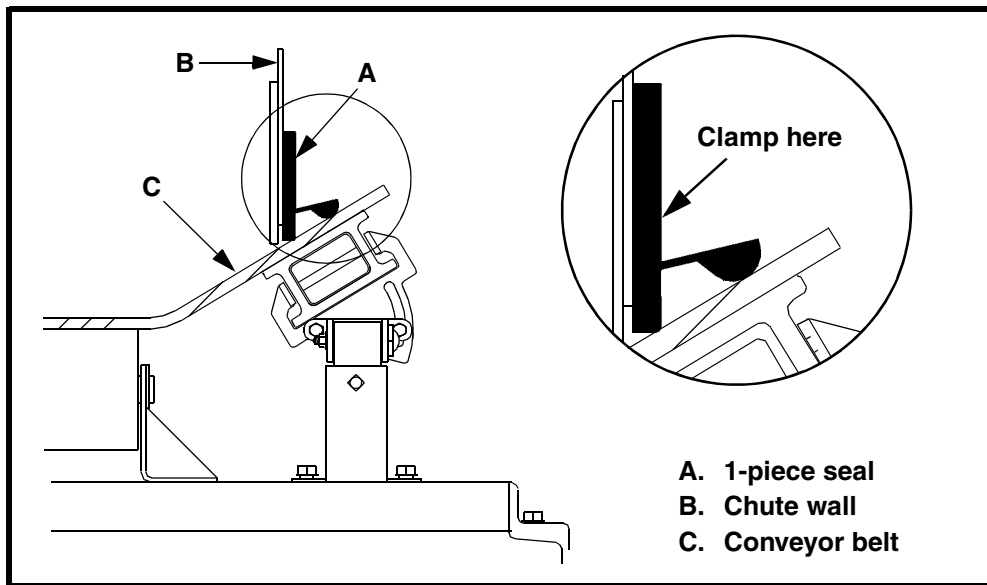

**Figure 2. Installing MARTIN<sup>®</sup> APRON SEAL<sup>™</sup> Skirting**

2. Place rubber seal (A) against chute wall (B).
3. Adjust seal so that it rests on conveyor belt (C). Do not force seal onto belt.

**IMPORTANT**

**If seal has a splice, additional clamps may be required at splice to maintain seal.**

4. Clamp seals to chute wall using MARTIN® Angle Clamps (see Appendix A). Refer to drawings that were included with clamps for installation instructions. If you are not using MARTIN® Angle Clamps, space clamps at 12-in. (305-mm) centers so that seal does not move while conveyor belt is running (loaded or unloaded).

**IMPORTANT**

**Do not use Permabond to splice thermoplastic rubber seals for food-grade applications. Permabond is not a food-grade adhesive.**

5. If you need to splice two or more lengths of rubber seals together, do the following:
  - a. Use the 1-Piece MARTIN® APRON SEAL™ Splice Kit (Rubber), P/N 34147.
  - b. Cut both ends to be bonded together at a 90° angle and clean both ends. (This 90° angle is critical because both pieces of skirting must be straight after bonding.)
  - c. Apply Permabond 268 to both ends and hold ends together for 1 minute.
6. If you need to splice two or more lengths of thermoplastic rubber together for food-grade application, do not apply Permabond. Instead, clamp seals in place with ends touching.

## After Installing MARTIN® APRON SEAL™ Skirting System

---

Thoroughly wipe chute wall clean above MARTIN® APRON SEAL™ Skirting System on both sides of chute. Place Conveyor Products Warning Label (P/N 23395) on outside chute walls visible to conveyor belt operator.

## Monthly Maintenance

---



### **⚠ WARNING**

**Before installing equipment, lock out/tag out energy source to conveyor and conveyor accessories.**

1. Turn off and lock out/tag out energy source according to ANSI standards (see “References”).

### **⚠ WARNING**

**Do not lift up secondary seal while conveyor belt is running or injury could result.**

2. Check seals for wear. Replace if necessary.
3. Make sure clamps are tight.
4. Make sure primary seal section is resting on conveyor belt and does not move.

# Part Numbers

---

This section provides product names and corresponding part numbers for MARTIN<sup>®</sup> APRON SEAL<sup>™</sup> Skirting Systems and related equipment. Please reference part numbers when ordering parts:

**MARTIN<sup>®</sup>  
APRON SEAL<sup>™</sup>  
Skirting System**

See Figure 3.

**MARTIN<sup>®</sup>  
Clamps**

- Angle Clamp Weldment (6 ft long):** P/N 32049.
- Angle Clamp Weldment With Hardware:** P/N 32049-H.
- Angle Clamp Weldment with Quick-Release Clamp and Hardware:** P/N 32049-QRH
- Low-Profile Angle Clamp Weldment:** P/N 32600.
- Low-Profile Angle Clamp Weldment With Hardware:** P/N 32600-H.
- Low-Profile Angle Clamp Weldment with Quick-Release Clamp and Hardware:** P/N 32600-QRH
- Heavy-Duty Angle Clamp Weldment:** P/N 34339.
- Heavy-Duty Angle Clamp Weldment With Hardware:** P/N 34339-H.

**Miscellaneous**

- DURT TAMER<sup>™</sup> Wear Liners:** P/N WL-XXXXXXXXXXXXX.  
First four Xs indicate the height of wear liner in inches; next four Xs indicate length of wear liner in inches; next three Xs indicate thickness of wear liner in inches; last X indicates wear liner material.
- 1-Piece MARTIN<sup>®</sup> APRON SEAL<sup>™</sup> Splice Kit (Rubber):** P/N 34147.
- Fabricated Chute Wall 12-in. Tall Assembly for MARTIN<sup>®</sup> APRON SEAL<sup>™</sup> Skirt Seal:** P/N 33564-XX. XX indicates troughing angle.
- Fabricated Chute Wall 24-in. Tall Assembly for MARTIN<sup>®</sup> APRON SEAL<sup>™</sup> Skirting:** P/N 34620-XX. XX indicates troughing angle.

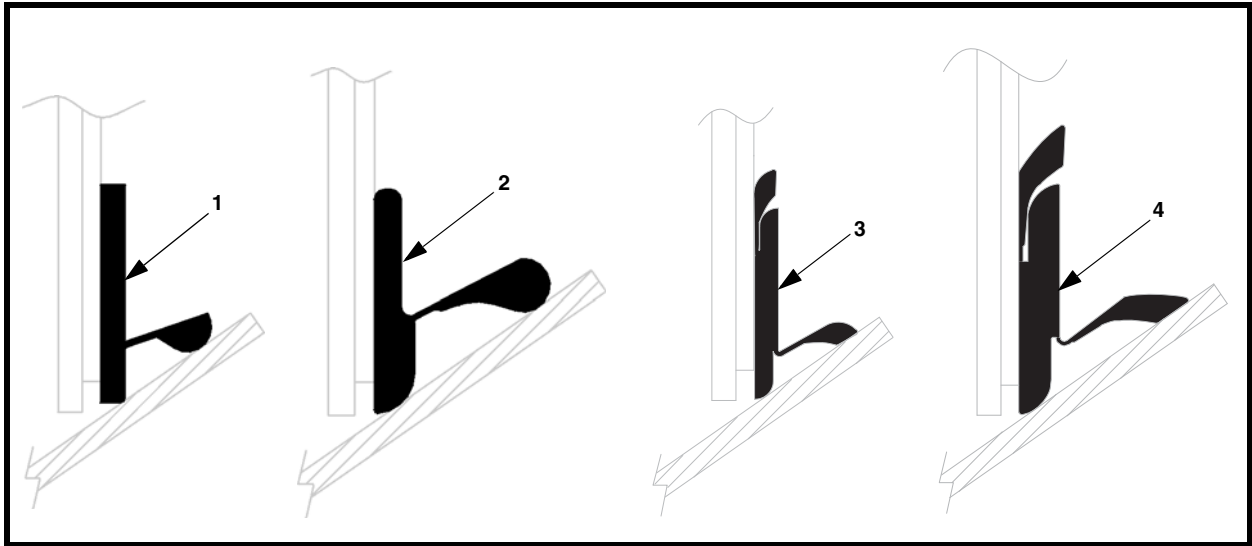

Figure 3. MARTIN® APRON SEAL™ Skirting System Assemblies

Item	Description	Part No.	Qty
1	MARTIN® APRON SEAL™ 1-Piece Skirt Seal	100724	1 ft
2	MARTIN® APRON SEAL™ Heavy-Duty 1-Piece Skirt Seal	100723	1 ft
3	MARTIN® Double APRON SEAL™ Standard-Duty Skirting	100873	1 ft
4	MARTIN® Double APRON SEAL™ Heavy-Duty Skirting	100861	1 ft
Fig. 4	Conveyor Products Warning Label	23395	2

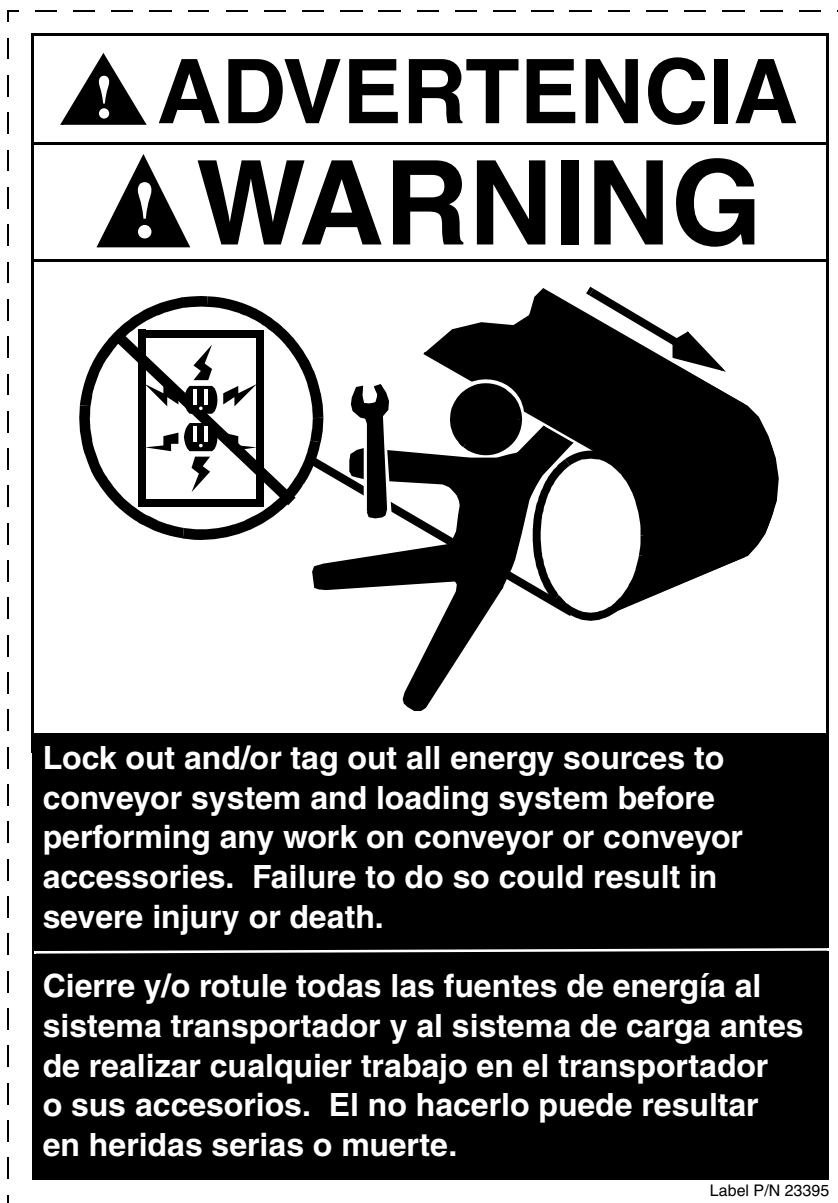
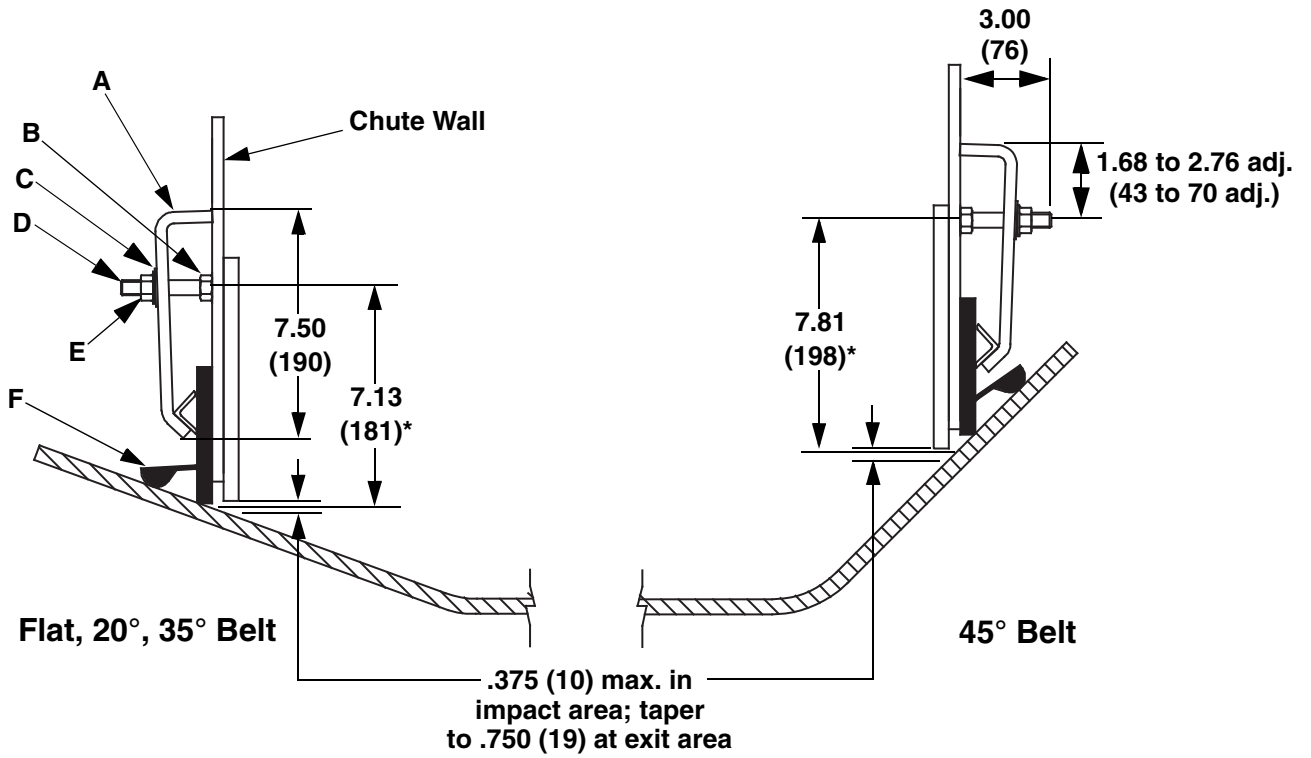

Figure 4. Conveyor Products Warning Label, P/N 23395



**Appendix A**  
**MARTIN<sup>®</sup> APRON SEAL<sup>™</sup> Skirting System Mounting Dimensions**

# Appendix A



- A. Angle Clamp Weldment, P/N 32049
- B. 1/2-in. -13NC Hex Nut, P/N 34134
- C. 1/2 Flat Washer, P/N 17328
- D. 1/2-in. -13NC x 3-in. Threaded Stud, P/N 31189

- E. 1/2-in. -13NC Locking Flange Nut, P/N 18843
- F. 1-Piece MARTIN® APRON SEAL™ Skirting, P/N 100724

\*Distance from center of mounting stud to point on belt directly below chute wall.

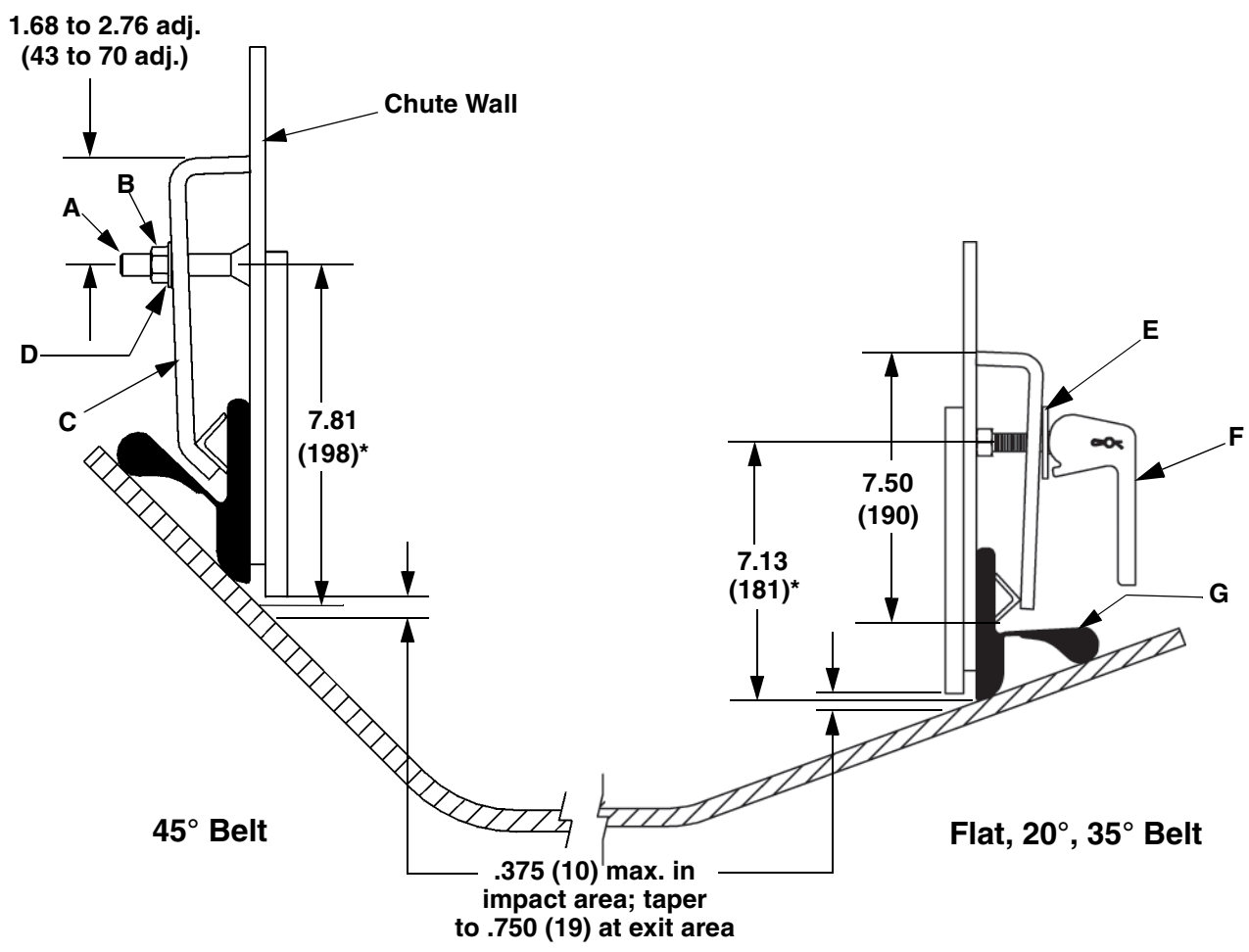

- A. Stud 1/2 x 13NC x 3.00, P/N 31189
- B. Nut Flange Locking 1/2 -13NC, P/N 18843
- C. Angle Clamp Weldment, P/N 32049
- D. 9/16 Flat Washer, P/N 17328
- E. 3/4 Flat Washer, P/N 20164
- F. Quick-Release Clamp, P/N 36273
- G. MARTIN® APRON SEAL™ 1-Piece Heavy-Duty Skirting, P/N 100723

\*Distance from center of mounting stud to point on belt directly below chute wall.

# Appendix A

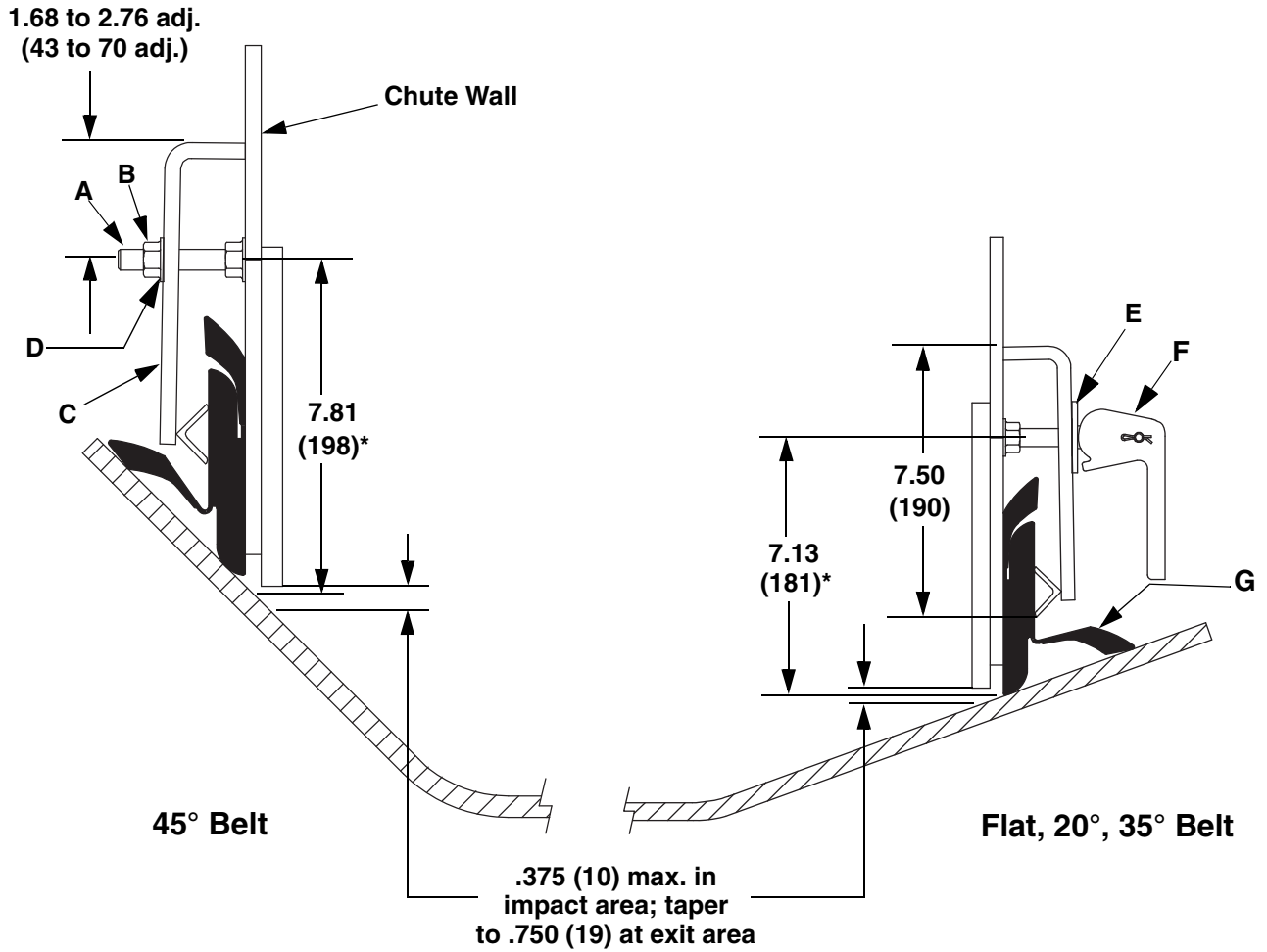



- A. Stud 1/2 x 13NC x 3.00, P/N 31189
- B. Nut Flange Locking 1/2 -13NC, P/N 18843
- C. Angle Clamp Weldment, P/N 32049
- D. 9/16 Flat Washer, P/N 17328
- E. 3/4 Flat Washer, P/N 20164
- F. Quick-Release Clamp, P/N 36273
- G. MARTIN® Double APRON SEAL™ Heavy-Duty Skirting, P/N 100861

\*Distance from center of mounting stud to point on belt directly below chute wall.

## Appendix B

### MARTIN<sup>®</sup> APRON SEAL<sup>™</sup> Skirting System Selection Guide

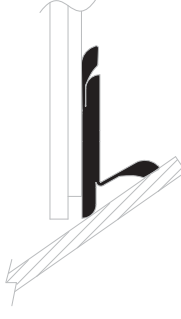
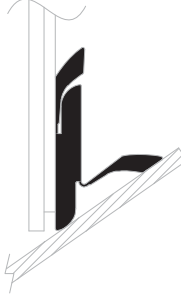
		Standard 1-Piece	Heavy-Duty 1-Piece	Standard Double	Heavy-Duty Double
Material		EPDM Rubber 70 Durometer Shore A	EPDM Rubber 70 Durometer Shore A	EPDM Rubber 70 Durometer Shore A	EPDM Rubber 70 Durometer Shore A
					
Minimum “Free Belt” Outside Skirtboard*	Flat Belt	2 in. (51 mm)	3 in. (76 mm)	2.14 in. (54 mm)	2.97 in. (76 mm)
	20° Trough	2.5 in. (63 mm)	3.5 in. (89 mm)	2.58 in. (66 mm)	3.74 in. (95 mm)
	35° Trough	3 in. (76 mm)	3.5 in. (89 mm)	2.87 in. (73 mm)	4.18 in. (106 mm)
	45° Trough	3.25 in. (83 mm)	4.125 in. (105 mm)	3.01 in. (77 mm)	4.38 in. (111 mm)
Maximum Belt Speed		600 fpm (3 m/s)	750 fpm (3.8 m/s)	600 fpm (3 m/s)	750 fpm (3.8 m/s)
Notes		Available in lengths up to 300 ft (91.5 m). High-temperature and food-grade materials available in lengths up to 24 ft (7.3 m).	Available in lengths up to 300 ft (91.5 m).	Available in lengths up to 300 ft (91.5 m). Double life sealing system in a one-piece construction.	Available in lengths up to 300 ft (91.5 m). Double life sealing system in a one-piece construction.

\* “Free Belt” is amount of belting visible outside the steel skirtboard on each side of the transfer point.



*Any product, process, or technology described here may be the subject of intellectual property rights reserved by Martin Engineering Company. Trademarks or service marks designated with the ® symbol are registered with the U.S. Patent and Trademark Office and may be proprietary in one or more countries or regions. Other trademarks and service marks belonging to Martin Engineering Company in the United States and/or other countries or regions may be designated with the “TM” and “SM” symbols. Brands, trademarks, and names of other parties, who may or may not be affiliated with, connected to, or endorsed by Martin Engineering Company, are identified wherever possible. Additional information regarding Martin Engineering Company’s intellectual property can be obtained at [www.martin-eng.com/trademarks](http://www.martin-eng.com/trademarks).*

# ***Problem Solved™***



**Martin Engineering USA**

One Martin Place  
Neponset, IL 61345-9766 USA  
800 544 2947 or 309 852 2384  
Fax 800 814 1553  
[www.martin-eng.com](http://www.martin-eng.com)

Subject to change without prior notice.

Quality Management System Certified by DNV - ISO 9001

**QUALITY MANAGEMENT SYSTEM  
CERTIFIED BY DNV**

**==== ISO 9001:2008 ====**