

APRON SEAL™ ON FLAT BELT

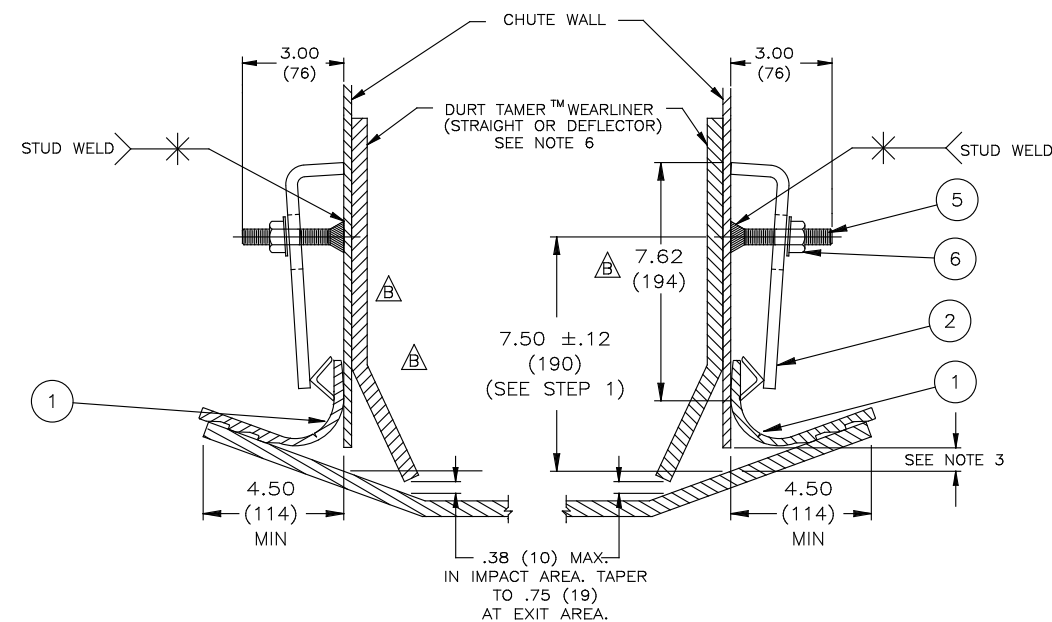

APRON SEAL™ ON 20° BELT

ITEM	QTY.	DESCRIPTION	PART NUMBER
1	12'	APRON SEAL™ 3.00 ASSEMBLY	100444-12
2	2	ANGLE CLAMP WELDMENT	32049
3	6'/12'	ANGLE 1 X 1 X 1/8	102118
4	*	STUD THREADED 1/2-13NC X 3	31189
5	**	NUT FLANGE LOCKING 1/2-13NC	18843

* - USE 1 PER EACH FOOT OF APRON SEAL™ SKIRTING
 ** - 2 OF 18843 ARE SUPPLIED PER FOOT, 1 IS USED TO HOLD THE ANGLE CLAMP IN PLACE ON THE STUD, THE OTHER CAN BE WELDED TO THE CHUTE WALL AND THEN INSERT THE STUD.
 B.O.M. SHOWS COMPONENTS USED IN APRON SEAL™ INSTALLATIONS. COMPONENTS CAN BE USED IN MANY COMBINATIONS.

INSTALLATION INSTRUCTIONS

- STEP 1: SCRIBE A LINE PARALLEL TO BELT SURFACE 7.50" (191) ABOVE BELT.
- STEP 2: ALONG THIS LINE, MAKE FIRST MARK 6.00"(152) FROM END OF CHUTE WALL AND MARK EVERY 12.00"(305).
- STEP 3: ON THESE MARKED CENTERS, WELD 1/2"-13NC x 3" STUDS. WHEN WELDING STUDS, MAKE SURE THAT THEY ARE WELDED PERPENDICULAR TO THE CHUTE WALL TO ENSURE EVEN CLAMP CONTACT.
- STEP 4: PLACE APRON SEAL™ RUBBER SEAL AGAINST CHUTE WALL. MAKING SURE THAT SKIRTING IS ALSO TOUCHING THE BELT, SLIDE CLAMPS OVER STUDS.
- STEP 5: PUSH ANGLE CLAMP WELDMENT TIGHT AGAINST SKIRTING AND INSTALL LOCKING NUT. TIGHTEN LOCKING NUT TO 40 FT/LBS.
- STEP 6: IF RUBBER SEAL HANGS OVER EDGE OF BELT, TRIM SEAL BACK BY CUTTING OFF EACH RIB UNTIL SEAL NO LONGER HANGS OVER BELT. A MINIMUM OF ONE RIB MUST REMAIN FOR PROPER SEALING.

NOTES:

- 1) ALL DIMENSIONS ARE GIVEN IN INCHES (MM).
- 2) ALL DIMENSIONS ARE SHOWN FOR REFERENCE PURPOSES ONLY.
- 3) MARTIN RECOMMENDS CHUTE WALL BEING WITHIN .75"(19) OF BELT.
- 4) SKIRTING CAN BE ADJUSTED INDIVIDUALLY PER CLAMP TO MEET VARIATIONS IN BELT PROFILE.
- 5) A MIN. 10"(254) VERTICAL AND 4"(102) HORIZONTAL CLEARANCE REQUIRED TO INSTALL SKIRTING AND CLAMPS.
- 6) TO PROVIDE AN EFFECTIVE SEAL, WEARLINERS ARE TO BE USED TO PREVENT THE MAIN LOAD FROM CONTACTING THE SKIRTING.
- 7) WHEN WEARLINERS ARE BOLTED TO CHUTE WALL. SKIRTING AND CLAMPS ARE TO BE MOUNTED IN A MANNER AS TO ALLOW EASY ACCESS TO BOLTS.
- 8) SKIRTING IS DESIGNED TO SEAT IN QUICKLY REGARDLESS OF TROUGH ANGLE.
- 9) SKIRTING IS PLIABLE ENOUGH TO STRETCH OR BEND AROUND WEARLINER BOLTS, SKIRTING CAN ALSO BE NOTCHED OUT AROUND BOLTS IF NECESSARY.
- 10) MARTIN APRON SEAL™ SKIRTING IS DESIGNED AS A DUST SEAL. IT IS NOT DESIGNED AS A MATERIAL HOLDBACK OR LOAD CARRYING SURFACE.
- 11) CONVEYOR BELT MUST NOT LIFT OFF IDLERS DURING STARTUP OR WHILE BELT IS RUNNING.
- 12) BELT MUST TRACK PROPERLY TO PREVENT BELT FROM RUNNING BEHIND SKIRTING.
- 13) FOR INSTALLATIONS WITH UNUSUAL OR SEVERE CONDITIONS: I.E. CONCAVE/CONVEX CURVES. EXTREME SIDE PRESSURE, EXTREMELY FAST OR SLOW BELTS, TEMPERATURE EXTREMES, CORROSIVE ATMOSPHERES, ETC., CONSULT MARTIN ENGINEERING CO.
- 14) SKIRTING AND WEARLINER SHOULD BEGIN AT LEAST 12"(305) PRIOR TO INLET SIDE OF TRANSFER CHUTE WALL.
- 15) ANY DEVIATION IN MOUNTING, OTHER THAN SHOWN, CUSTOMER SHOULD CONSULT MARTIN ENGINEERING.
- 16) CLAMP IS TO BE FULLY TIGHTENED AGAINST CHUTE WALL.
- 17) CLAMP MUST HAVE FIRM BACKING TO INSURE PROPER CLAMP FORCE.

NOTE: REFER TO O/O MANUAL M3248 DURING INSTALLATION. THIS IS NOT A SUBSTITUTE FOR O/O MANUAL.

© Copyright 1993 Martin Engineering. All rights reserved. Covered by U.S. and foreign patents pending and issued. ® and TM indicate trademarks of Martin Engineering.

MARTIN ENGINEERING

NEPONSET
ILLINOIS
USA

B	RMV DIM 7.64 (2 PLACES) AND 6.75 (2 PLACES)/CHG DIM FROM 7.50 TO 7.62 (2 PLACES)/RMV P/N 29080-02 FROM BOM/CHG QTY FROM 1 TO 2 ON P/N 32049/CHG INSTALLATION INSTRUCTIONS/UPDATED P/N 32049 PICTORIAL DUE TO CHG	9929	05/03/01	CGH	TITLE	INSTALLATION DRAWING FOR ANGLE & TORSION ARM CLAMP WITH RUBBER APRON SEAL™	DRAWN TEV DATE 01/22/93
	A	UPDATED BOM/CHANGED 18843 FROM QTY OF 1 PER FOOT TO 2 PER FOOT	7014	10/31/95	JAP	SALES DRAWING	ENG. JLD DATE 05/10/01
NO.	DESCRIPTION	ECN	DATE	BY	S32247-R		APPROVED JRB DATE 05/11/01
REVISION					L:\SAL\S32247-R		SCALE 1/4