

ITEM	QTY.	DESCRIPTION	PART NUMBER
1	***	APRON SEAL™ 1-PIECE	100724
2	*	ANGLE CLAMP WELDMENT	32600
3	**	QUICK RELEASE CLAMP ASSEMBLY	36273
4	**	ROD THREADED 1/2-13NC X 3	31189
5	**	NUT HEX 1/2-13NC PLAIN	34134

SEE NOTE 20

\* - EACH WELDMENT IS 71.88 (1826) LONG. ONE WELDMENT IS REQUIRED PER EVERY 6' (1829) OF APRON SEAL™ (P/N 100724)  
 \*\* - USE ONE PER EACH FOOT OF APRON SEAL™  
 \*\*\* - CUT TO LENGTH.

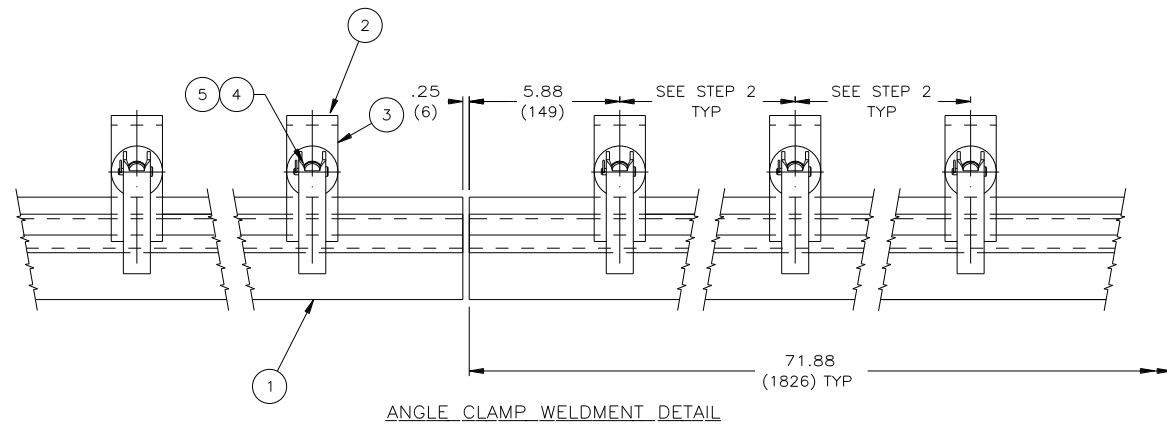

**INSTALLATION INSTRUCTIONS**

- STEP 1: SCRIBE A LINE ON CHUTE WALL PARALLEL TO BELT SURFACE 5.25 (133) ABOVE BELT.
- STEP 2: ALONG THIS LINE, MAKE FIRST MARK 5.88 (149) FROM END OF CHUTE WALL AND MARK EVERY 12.00 (305) AFTER THAT.
- STEP 3: ON THESE MARKED CENTERS, WELD 1/2-13NC x 3 THREADED RODS. WHEN WELDING RODS, MAKE SURE THAT THEY ARE WELDED PERPENDICULAR TO THE CHUTE WALL TO ENSURE EVEN CLAMP CONTACT.
- STEP 4: INSTALL 1-PIECE APRON SEAL™ AND PLACE AGAINST CHUTE WALL. MAKING SURE THAT SKIRTING IS ALSO TOUCHING THE BELT, SLIDE CLAMPS OVER RODS.
- STEP 5: PUSH ANGLE CLAMP WELDMENT TIGHT AGAINST SKIRTING AND INSTALL QUICK RELEASE CLAMP.

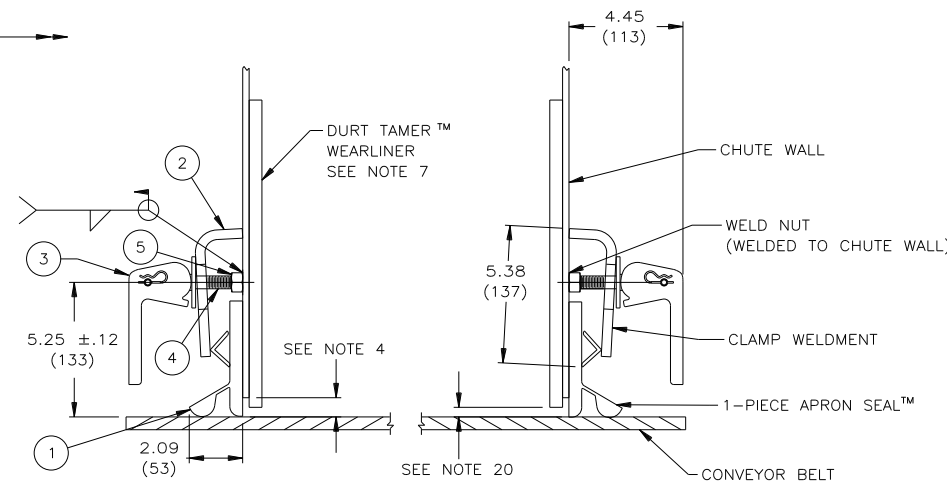

**DETAIL FOR FLAT BELTS**

(ALL DIMENSIONS TYPICAL EACH SIDE OF CONVEYOR)

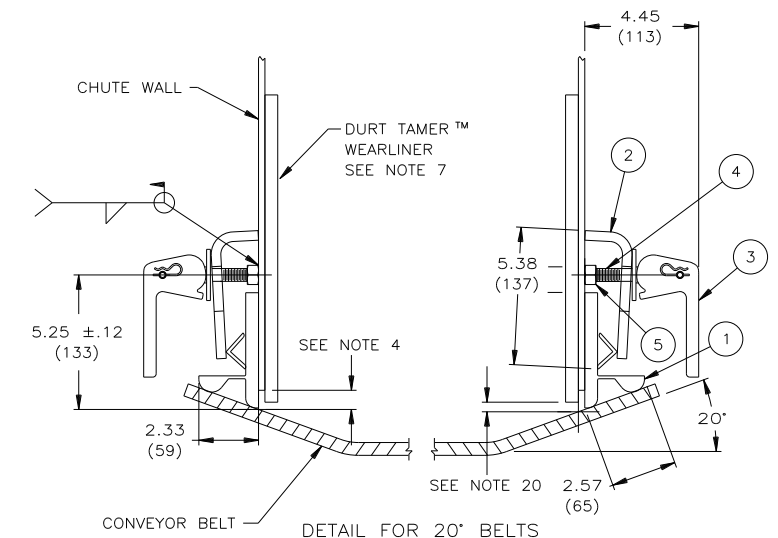

**DETAIL FOR 20° BELTS**

(ALL DIMENSIONS TYPICAL EACH SIDE OF CONVEYOR)

**NOTE:**

- 1) ALL DIMENSIONS ARE GIVEN IN INCHES (MM).
- 2) UNLESS OTHERWISE SPECIFIED ALL INCH DIMENSIONS ARE FOR REFERENCE PURPOSES ONLY.
- 3) (MM) ARE SHOWN FOR REFERENCE PURPOSES ONLY. ACTUAL (MM) VALUES AND TOLERANCES SHOULD BE DERIVED FROM INCH VALUES GIVEN.
- 4) MARTIN ENGINEERING RECOMMENDS CHUTE WALL TO BE WITHIN .75 (19) OF BELT.
- 5) APRON SEAL™ CAN BE ADJUSTED INDIVIDUALLY PER CLAMP TO MEET VARIATIONS IN BELT PROFILE.
- 6) A MIN OF 8.00 (203) VERTICAL AND 4.00 (102) HORIZONTAL CLEARANCE REQUIRED TO INSTALL APRON SEAL™ & CLAMPS.
- 7) TO PROVIDE AN EFFECTIVE SEAL, DURT TAMER™ WEARLINERS ARE RECOMMENDED TO PREVENT THE MAIN LOAD FROM CONTACTING THE APRON SEAL™.
- 8) IF DURT TAMER™ WEARLINERS ARE BOLTED TO CHUTE WALL, APRON SEAL™ & CLAMPS ARE TO MOUNTED IN A MANNER AS TO ALLOW EASY ACCESS TO BOLTS.
- 9) 1-PIECE APRON SEAL™ IS DESIGNED AS A DUST SEAL ONLY. IT IS NOT TO BE USED AS A MATERIAL HOLDBACK OR LOAD CARRYING SURFACE.
- 10) BELT MUST NOT LIFT OFF IDLERS DURING START-UP OR WHILE BELT IS IN OPERATION.
- 11) BELT MUST TRACK PROPERLY TO PREVENT IT FROM RUNNING BEHIND APRON SEAL™.
- 12) APRON SEAL™ IS DESIGNED TO SEAT IN QUICKLY REGARDLESS OF TROUGH ANGLE.
- 13) APRON SEAL™ IS PLIABLE ENOUGH TO STRETCH OR BEND AROUND DURT TAMER™ WEARLINER BOLTS. APRON SEAL™ CAN ALSO BE NOTCHED OUT AROUND BOLTS IF NECESSARY.
- 14) CONSULT MARTIN ENGINEERING FOR INSTALLATIONS WITH UNUSUAL OR SEVERE CONDITIONS, IE: CONCAVE/CONVEX CURVES, EXTREME SIDE PRESSURE, UNUSUALLY FAST OR SLOW MOVING BELTS, TEMPERATURE EXTREMES, ETC.
- 15) APRON SEAL™ AND DURT TAMER™ WEARLINER SHOULD BEGIN AT LEAST 12.00 (305) BEFORE INLET SIDE OF CHUTE WALL.
- 16) CONTACT MARTIN ENGINEERING PRIOR TO MOUNTING THESE PRODUCTS IN ANY WAY OTHER THAN WHAT IS DEPICTED ON THIS DRAWING OR IN OPERATOR'S MANUAL.
- 17) ANGLE CLAMP WELDMENT (P/N 32600) IS TO BE FULLY TIGHTENED AGAINST CHUTE WALL.
- 18) ANGLE CLAMP WELDMENT MUST HAVE FIRM BACKING TO ENSURE PROPER CLAMP FORCE.
- 19) .38 (10) MAX IN IMPACT AREA, TAPERING TO .75 (19) AT EXIT AREA.
- 20) QUICK RELEASE CLAMP (P/N 36273) HANDLE CAN BE LOCKED INTO ANY ORIENTATION.

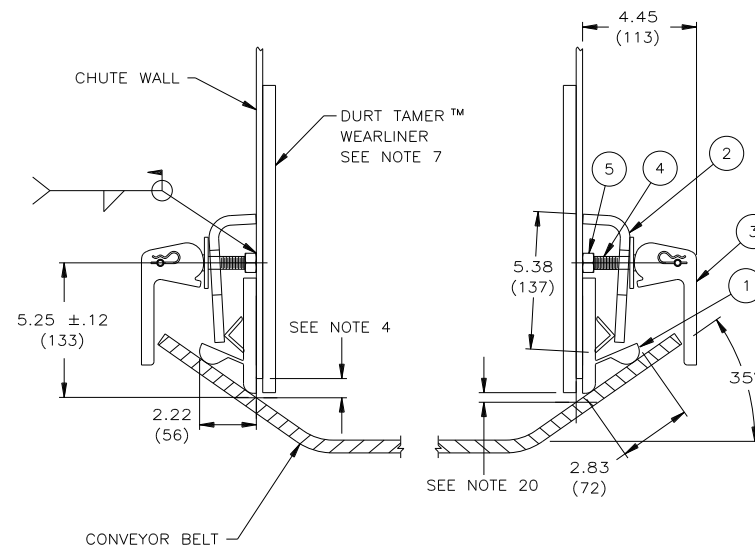

**DETAIL FOR 35° BELTS**

(ALL DIMENSIONS TYPICAL EACH SIDE OF CONVEYOR)

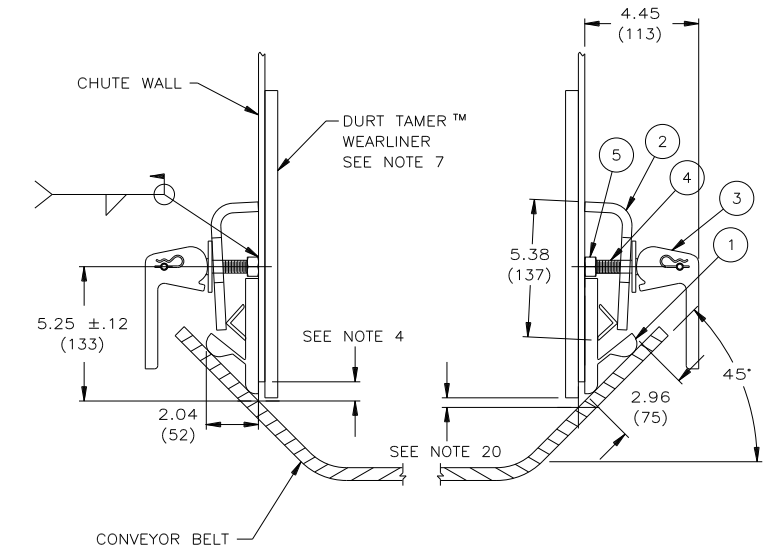

**DETAIL FOR 45° BELTS**

(ALL DIMENSIONS TYPICAL EACH SIDE OF CONVEYOR)

© Copyright 2002 Martin Engineering. All rights reserved. Covered by U.S. and foreign patents pending and issued. ® and ™ indicate trademarks of Martin Engineering.

**MARTIN ENGINEERING** NEPONSET ILLINOIS USA

TITLE	INSTALLATION DRAWING FOR LOW PROFILE ANGLE CLAMP W/1-PIECE APRON SEAL™ & QUICK RELEASE CLAMP	DRAWN MJB DATE 08/20/02
ENG.	JAP DATE 08/20/02	CHECKED
APPROVED	JRB DATE 08/20/02	
SALES DRAWING	S37456	SCALE 1/4=1

NO.	DESCRIPTION	ECN	DATE	BY
	REVISION			