

ASSEMBLY PART NO.	BELT WIDTH	DIM "A" FRAME LENGTH	DIM "B" CARTRIDGE LENGTH	DIM "C" SPLIT-TRACK LENGTH	DIM "D" BLADE COVERAGE	BLADE QTY
DT2S-18X12XXXX	18.00 [457]	49.50 [1257]	36.16 [918]	27.00 [686]	12.00 [305]	4
DT2S-18X18XXXX	18.00 [457]	49.50 [1257]	36.16 [918]	27.00 [686]	18.00 [457]	6
DT2S-24X18XXXX	24.00 [610]	55.50 [1410]	42.16 [1071]	33.00 [838]	18.00 [457]	6
DT2S-24X24XXXX	24.00 [610]	55.50 [1410]	42.16 [1071]	33.00 [838]	24.00 [610]	8
DT2S-30X24XXXX	30.00 [762]	61.50 [1562]	48.16 [1223]	39.00 [991]	24.00 [610]	8
DT2S-30X30XXXX	30.00 [762]	61.50 [1562]	48.16 [1223]	39.00 [991]	30.00 [762]	10
DT2S-36X30XXXX	36.00 [914]	67.50 [1715]	54.16 [1376]	45.00 [1143]	30.00 [762]	10
DT2S-36X36XXXX	36.00 [914]	67.50 [1715]	54.16 [1376]	45.00 [1143]	36.00 [914]	12
DT2S-42X36XXXX	42.00 [1067]	73.50 [1867]	60.16 [1528]	51.00 [1295]	36.00 [914]	12
DT2S-42X42XXXX	42.00 [1067]	73.50 [1867]	60.16 [1528]	51.00 [1295]	42.00 [1067]	14
DT2S-48X42XXXX	48.00 [1219]	79.50 [2019]	66.16 [1680]	57.00 [1448]	42.00 [1067]	14
DT2S-48X48XXXX	48.00 [1219]	79.50 [2019]	66.16 [1680]	57.00 [1448]	48.00 [1219]	16
DT2S-54X48XXXX	54.00 [1372]	85.50 [2172]	72.16 [1833]	63.00 [1600]	48.00 [1219]	16
DT2S-54X54XXXX	54.00 [1372]	85.50 [2172]	72.16 [1833]	63.00 [1600]	54.00 [1372]	18
DT2S-60X54XXXX	60.00 [1524]	91.50 [2324]	78.16 [1985]	69.00 [1753]	54.00 [1372]	18
DT2S-60X60XXXX	60.00 [1524]	91.50 [2324]	78.16 [1985]	69.00 [1753]	60.00 [1524]	20
DT2S-66X60XXXX	66.00 [1676]	97.50 [2477]	84.16 [2138]	75.00 [1905]	60.00 [1524]	20
DT2S-66X66XXXX	66.00 [1676]	97.50 [2477]	84.16 [2138]	75.00 [1905]	66.00 [1676]	22
DT2S-72X66XXXX	72.00 [1829]	103.50 [2629]	90.16 [2290]	81.00 [2057]	66.00 [1676]	22
DT2S-84X78XXXX	84.00 [2134]	115.50 [2934]	102.16 [2595]	93.00 [2362]	78.00 [1981]	26
DT2S-96X90XXXX	96.00 [2438]	127.50 [3239]	114.16 [2900]	105.00 [2667]	90.00 [2286]	30
DT2S-120X114XXXX	120.00 [3048]	151.50 [3848]	138.16 [3509]	123.00 [3124]	114.00 [2896]	38

TENSIONING CHART	
BELT WIDTH	COMPRESSED SPRING LENGTH
18-24 [400-650]	1-5/8 [41]
30-48 [650-1400]	1-1/2 [38]
54-66 [1400-1800]	1-3/4 [45]
72-96 [1800-2400]	1-5/8 [41]
102-120 [2400-3000]	1-1/2 [38]

ITEM	QTY.	DESCRIPTION	PART NUMBER
1	1	DT SPLIT TRACK SECONDARY ASM	DT2S-XXXXXXXS
2	1	INLINE/REV SPRING TENSIONER	37707
3	S/C	REPLACEMENT BLADE	36316-T
4	1	DOOR CYA® 9.00 X 12.00	27658-0912
5	1	"Z" BRACKET PAIR W/HARDWARE	31158-01

S/C = SEE CHART

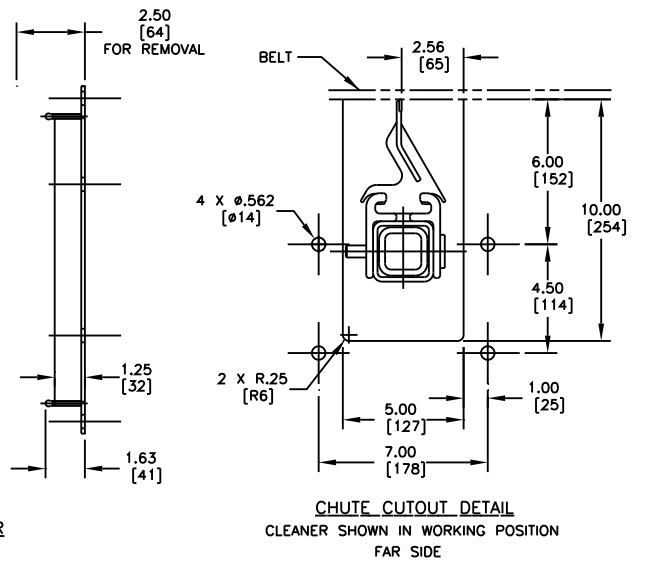
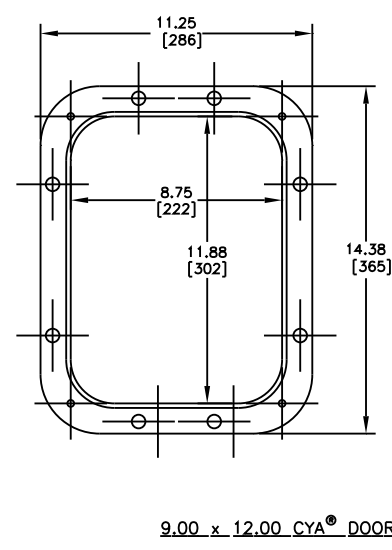
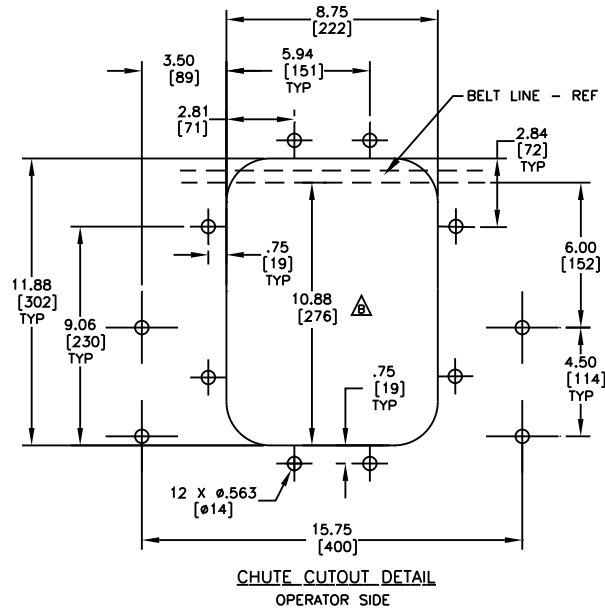
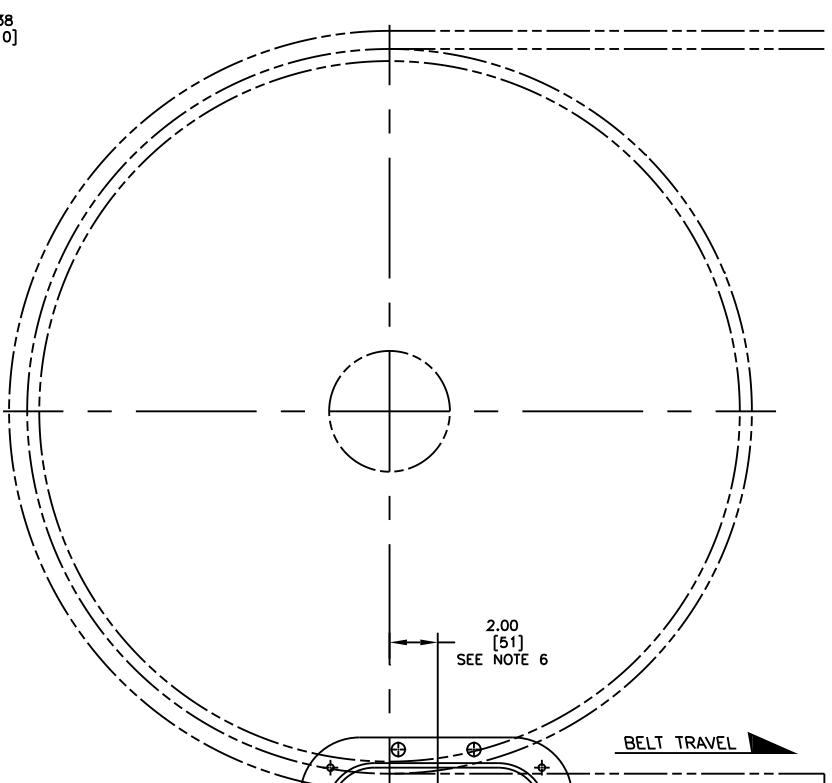
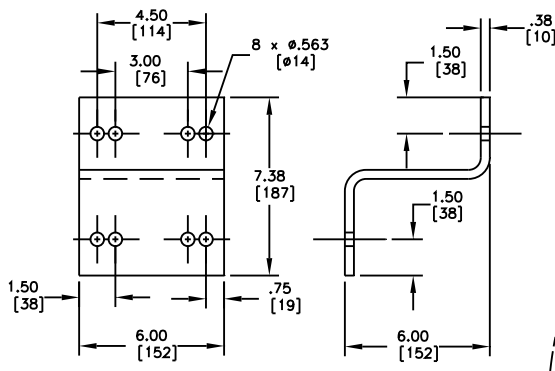

- NOTES:
- ALL DIMENSIONS ARE GIVEN IN INCHES (MM).
 - ALL DIMENSIONS ARE FOR REFERENCE PURPOSES ONLY.
 - WHEN INSTALLING TENSIONER, BOLT "Z" BRACKET TO TENSIONER FIRST THEN BOLT TENSIONER WITH "Z" BRACKET TO CHUTEWALL.
 - WHERE EXTREME OR UNUSUAL CONDITIONS EXIST OR SPECIAL MAINFRAME LENGTHS ARE REQUIRED CONSULT MARTIN ENGINEERING FOR ASSISTANCE.
 - REFER TO OPERATOR'S MANUAL M3687 FOR INSTALLATION DETAILS.
 - IF INSTALLED ON CROWN PULLEY, CLEANER IS RECOMMENDED TO BE 4.00 (102) FROM THE CENTERLINE. IT IS IMPORTANT THAT THE BELT IS LEVEL. IF IT IS NOT, INCREASE DIMENSION UNTIL LEVEL.
 - CLEANER MUST BE MOUNTED WITH BLADES PERPENDICULAR TO BELT SURFACE.
 - CENTER BLADES ON BELT SURFACE.
 - THERE WILL BE APPROXIMATELY .50" GAP BETWEEN BLADE TIP AND BELT FOR UNTENSIONED SPRING.
 - THE FIRST -XX IN SUFFIX INDICATES BELT WIDTH.
 - THE NEXT XX INDICATES BLADE TYPE:
 - O = NO BLADES
 - A = INLINE TC BLADE
 - T = TUNGSTEN CARBIDE REVERSING BLADE
 - S = STAINLESS STEEL REVERSING BLADE
 - U = URETHANE REVERSING BLADE
 - THE NEXT XX INDICATES BLADE COVERAGE.
 - OO = NO BLADES
 - THE NEXT XX INDICATES BLADE COLOR:
 - OO = NO BLADES
 - BR = BROWN
 - GR = GREEN
 - OR = ORANGE
 - THE NEXT X INDICATES MAINFRAME TYPE:
 - P = STANDARD DUTY
 - S = 316 STAINLESS STEEL
 - THE LAST X INDICATES ACCESSORY OPTIONS:
 - O = NO TENSIONER
 - A = INLINE/REV AIR TENSIONER
 - S = INLINE/REV SPRING TENSIONER

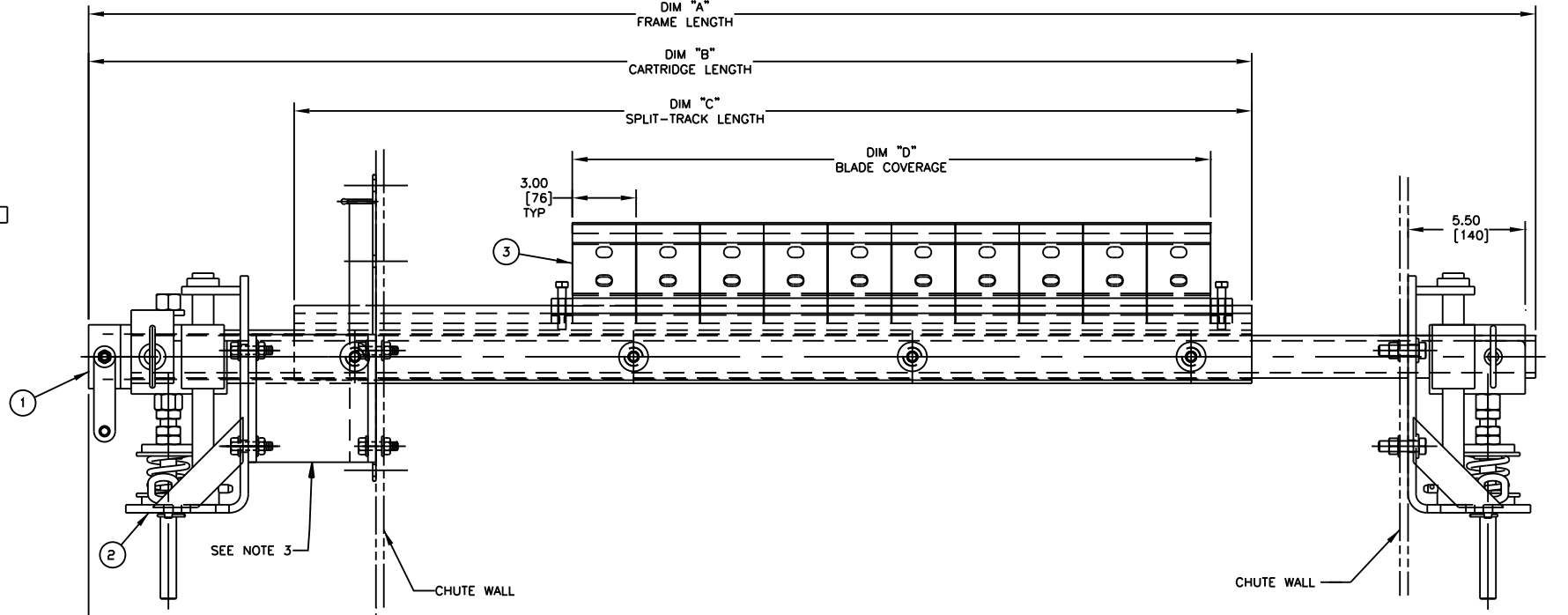

NO.	DESCRIPTION	ECN	DATE	BY
F	RWVD "NUMBER OF TURNS" FROM THE TENSIONING CHART	12348	07/10/08	MJB
E	UPDATED THE TENSIONING CHART	11983	04/12/07	MJB
D	UPDATED THE TENSIONING CHART	11776	09/07/06	MJB
C	RWVD P/N DT2S-XXBXXXXX FROM BLADE CHART AND NOTES	11650	08/02/06	MJB
B	ADDED DIM 10.88 [276] TO CHUTE CUTOUT DETAIL	-----	12/06/05	JMM
A	CHGD NOTE	11503	11/16/05	MJB

© Copyright 2005 Martin Engineering. All rights reserved. Covered by U.S. and foreign patents pending and issued. ® and TM indicate trademarks of Martin Engineering.

MARTIN ENGINEERING NEPONSET ILLINOIS USA

TITLE	DT2S ASM W/INLINE BLADES, SPRING TENS. "Z" BRACKET & DOOR	DRAWN JAP	DATE 09/06/05
SALES DRAWING	S50017-ISZ	CHECKED	DATE 09/07/05
APPROVED		APPROVED	DATE 09/07/05
SCALE	1/4"=1"		