

MAINFRAME ASM P/N	BELT WIDTH	DIMENSION "A" BLADE COVERAGE	DIMENSION "B" FRAME LENGTH	LONG ARM QUANTITY	SHORT ARM QUANTITY
37144-18XXX-X	18.00 [400-500]	12.50 [318]	40.00 [1016]	1	1
37144-24XXX-X	24.00 [500-650]	18.50 [470]	46.00 [1168]	1	2
37144-30XXX-X	30.00 [650-800]	24.50 [622]	58.00 [1473]	2	2
37144-36XXX-X	36.00 [800-1000]	30.50 [775]	64.00 [1626]	2	3
37144-42XXX-X	42.00 [1000-1200]	36.50 [927]	70.00 [1778]	3	3
37144-48XXX-X	48.00 [1200-1400]	42.50 [1080]	76.00 [1930]	3	4
37144-54XXX-X *	54.00 [1400-1600]	48.50 [1232]	82.00 [2083]	4	4
37144-60XXX-X *	60.00 [1600-1800]	54.50 [1384]	94.00 [2388]	4	5
37144-66XXX-X *	66.00 [1600-1800]	60.50 [1537]	100.00 [2540]	5	5
37144-72XXX-X *	72.00 [1800-2000]	66.50 [1689]	106.00 [2692]	5	6
37144-84XXX-X *	84.00 [2000-2200]	78.50 [1994]	123.00 [3124]	6	7

\* SEE NOTE 2

BLADE CHART				
ASSEMBLY P/N	SHORT ARM P/N	LONG ARM P/N	BLADE P/N	BLADE MATERIAL
37144-XXS-X	29033-S	29033-L	35380-01	BLADE 304 SS
37144-XXM-X	29033-S	29033-L	30339	BLADE MILD STEEL
37144-XXT-X	29033-S	29033-L	34574	T BLADE TUNGSTEN CARBIDE
37144-XXTBR-X	29033-SBR	29033-LBR	34574	T BLADE TUNGSTEN CARBIDE
37144-XXTGR-X	29033-SGR	29033-LGR	34574	T BLADE TUNGSTEN CARBIDE
37144-XXMT-X	29033-S	29033-L	35379	T BLADE MILD STEEL

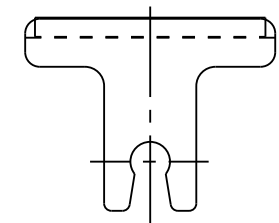
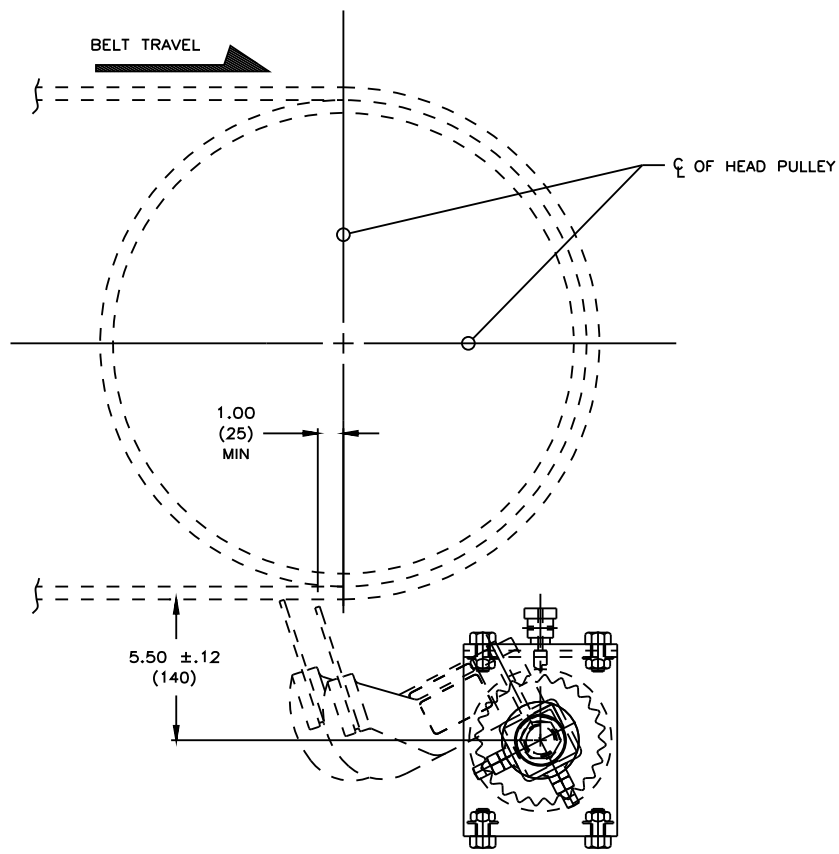

TUNGSTEN CARBIDE "T" BLADE DETAIL  
PART NUMBER 34574  
SCALE: 3/8

- NOTES:
- 1) ALL DIMENSIONS GIVEN IN INCHES (MM) AND ARE FOR REFERENCE ONLY.
  - 2) FOR BELT WIDTHS 54.00 (1400-1600) AND ABOVE, MARTIN ENGINEERING RECOMMENDS USING A DUAL TWIST TENSIONER ASSEMBLY (P/N 31443-2R).
  - 3) FOR P/N 37144-XXXXX-X, THE FIRST XX INDICATES BELT WIDTH. THE NEXT TWO XX'S INDICATE BLADE TYPE/MATERIAL. THE NEXT TWO XX'S INDICATE ARM COLOR. THE LAST X INDICATES TWIST TENSIONER (T) OR SPRING TENSIONER (S). LEFT BLANK FOR NO TENSIONER.
  - 4) WHERE EXTREME OR UNUSUAL CONDITIONS EXIST, OR SPECIAL MAINFRAME LENGTHS ARE REQUIRED, CONSULT MARTIN ENGINEERING FOR ASSISTANCE.
  - 5) CLEANER SHOWN IN UNTENSIONED POSITION.
  - 6) TWIST TENSIONER ASSEMBLY MAY BE BOLTED OR WELDED IN PLACE. MARTIN ENGINEERING RECOMMENDS BOLTING WHEN APPLICABLE FOR EASIER MAINTENANCE AND ACCESSIBILITY.
  - 7) BLADE COVERAGE WILL BE 5.50 (140) LESS THAN BELT WIDTH, DUE TO POSSIBLE MISTRACKING OF BELT OR DAMAGED EDGES OF BELT. BLADES MUST BE CENTERED ON BELT SURFACE.
  - 8) REFER TO OPERATOR'S MANUALS (P/N:M3296, M3619) FOR INSTALLATION DETAILS.
  - 9) SEVERE APPLICATIONS MAY REQUIRE ADAPTER TO BE WELDED TO MAINFRAME.
  - 10) FRAME IS ADJUSTABLE TO DESIRED LENGTH.

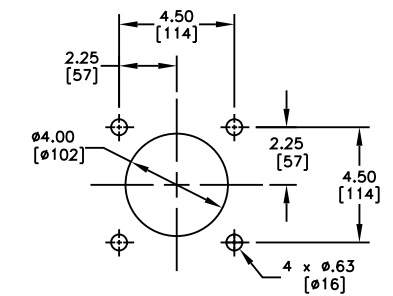

TENSIONER CHUTE WALL CUTOUT DETAIL  
TYPICAL BOTH SIDES

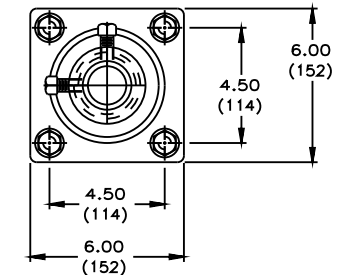

FARSIDE MOUNT

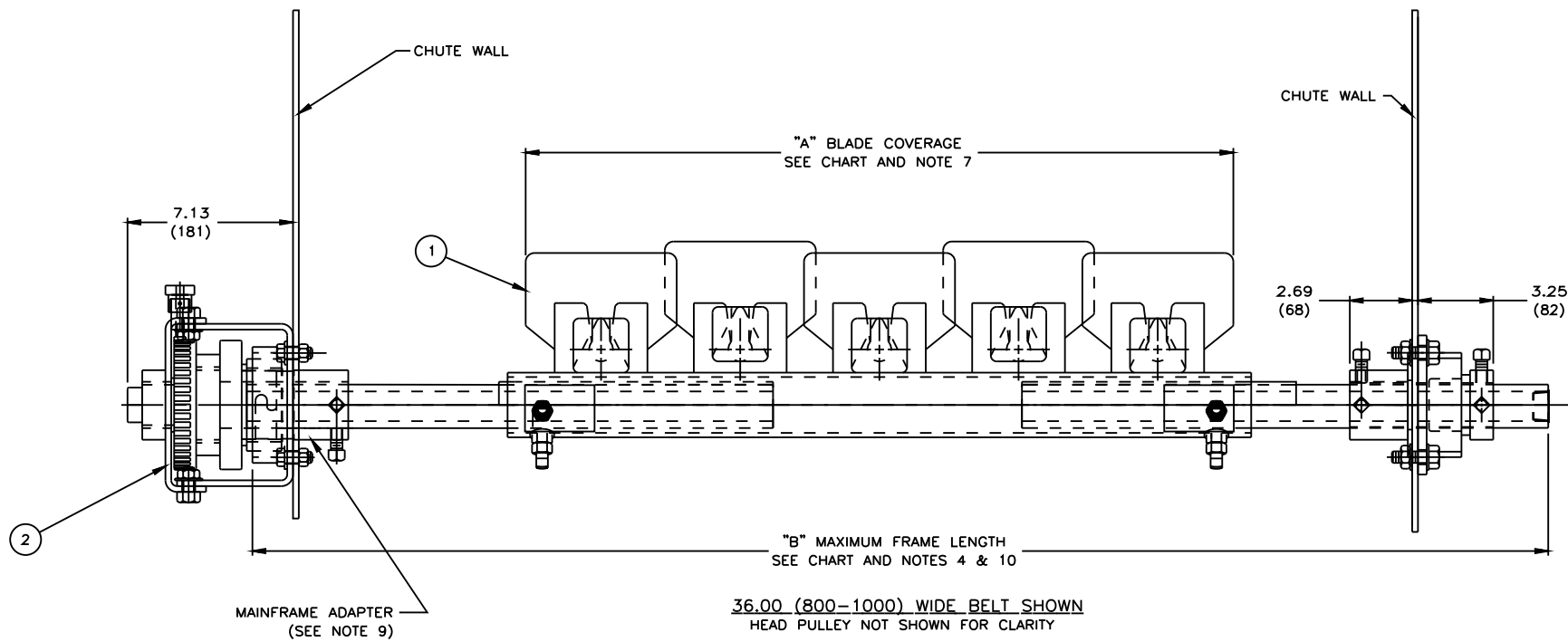

© Copyright 2002 Martin Engineering. All rights reserved. Covered by U.S. and foreign patents pending and issued. ® and TM indicate trademarks of Martin Engineering.

**MARTIN ENGINEERING** NEPONSET ILLINOIS USA

E	CHG 4.63 TO 4.00 IN CUTOUT DETAIL	----	03/13/07	JAP
D	RWVD P/N 37144-XXST-X FROM CHART	11609	03/24/06	MJB
C	RWV P/N 37144-XXT-X FROM CHART/CHG P/N FROM 30337 TO 34574 ON 37144-XXT-X, -XXTBR-X, -XXTGR-X	11349	05/13/05	MJB
B	CHG P/N FROM 35380 TO 35380-01 ON P/N 37144-XXS-X	11147	09/29/04	MJB
A	CHG P/N FROM 30340 TO 35380 ON P/N 37144-XXS-X	11121	08/18/04	MJB

NO.	DESCRIPTION	ECN	DATE	BY
	REVISION			

TITLE: DURT HAWG® HAWG BONE™ SECONDARY ASM  
 SALES DRAWING: S37435-S  
 DATE: 07/17/02  
 CHECKED: [Signature]  
 APPROVED: [Signature]  
 SCALE: 1/4