

ITEM	QTY.	DESCRIPTION	PART NUMBER
1	12'	APRON SEAL™ 3.00 ASSEMBLY	100444-12
2	2	ANGLE CLAMP WELDMENT	32049
3	*	QUICK RELEASE CLAMP ASSEMBLY	36273
4	*	ROD THREADED 1/2-13NC X 3	31189
5	*	NUT HEX 1/2-13NC PLAIN	34134

SEE NOTE 18

\* - USE 1 PER EACH FOOT OF APRON SEAL™ SKIRTING

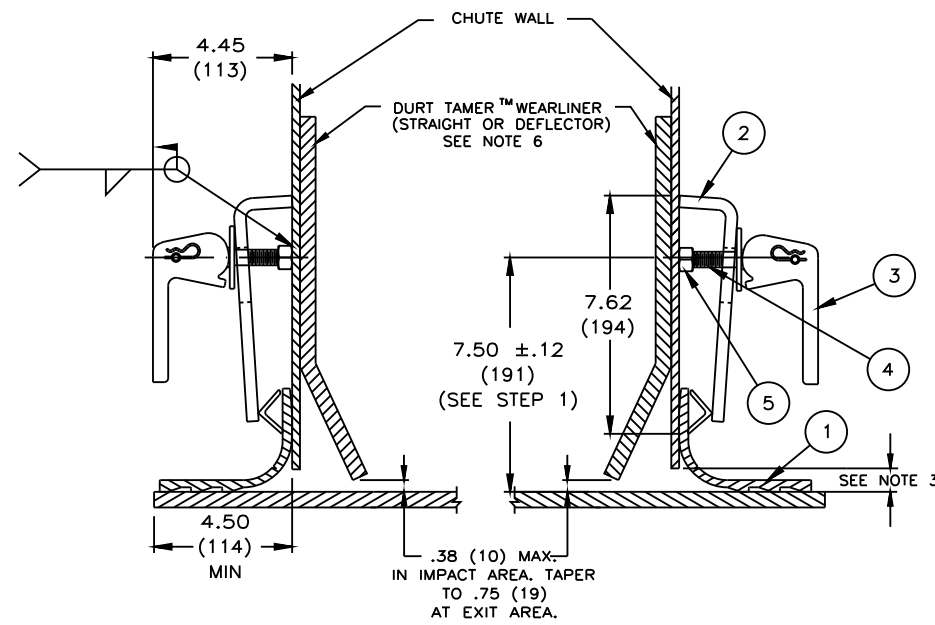

**APRON SEAL™ ON FLAT BELT**

(ALL DIMENSIONS TYPICAL EACH SIDE OF CONVEYOR)

**INSTALLATION INSTRUCTIONS**

- STEP 1: SCRIBE A LINE PARALLEL TO BELT SURFACE 7.50" (191) ABOVE BELT.
- STEP 2: ALONG THIS LINE, MAKE FIRST MARK 6.00"(152) FROM END OF CHUTE WALL AND MARK EVERY 12.00" (305).
- STEP 3: ON THESE MARKED CENTERS, WELD 1/2"-13NC x 3" THREADED RODS. WHEN WELDING RODS, MAKE SURE THAT THEY ARE WELDED PERPENDICULAR TO THE CHUTE WALL TO ENSURE EVEN CLAMP CONTACT.
- STEP 4: PLACE APRON SEAL™ RUBBER SEAL AGAINST CHUTE WALL. MAKING SURE THAT SKIRTING IS ALSO TOUCHING THE BELT, SLIDE CLAMPS OVER RODS.
- STEP 5: PUSH ANGLE CLAMP WELDMENT TIGHT AGAINST SKIRTING AND INSTALL THE QUICK RELEASE CLAMP.
- STEP 6: IF RUBBER SEAL HANGS OVER EDGE OF BELT, TRIM SEAL BACK BY CUTTING OFF EACH RIB UNTIL SEAL NO LONGER HANGS OVER BELT. A MINIMUM OF ONE RIB MUST REMAIN FOR PROPER SEALING.

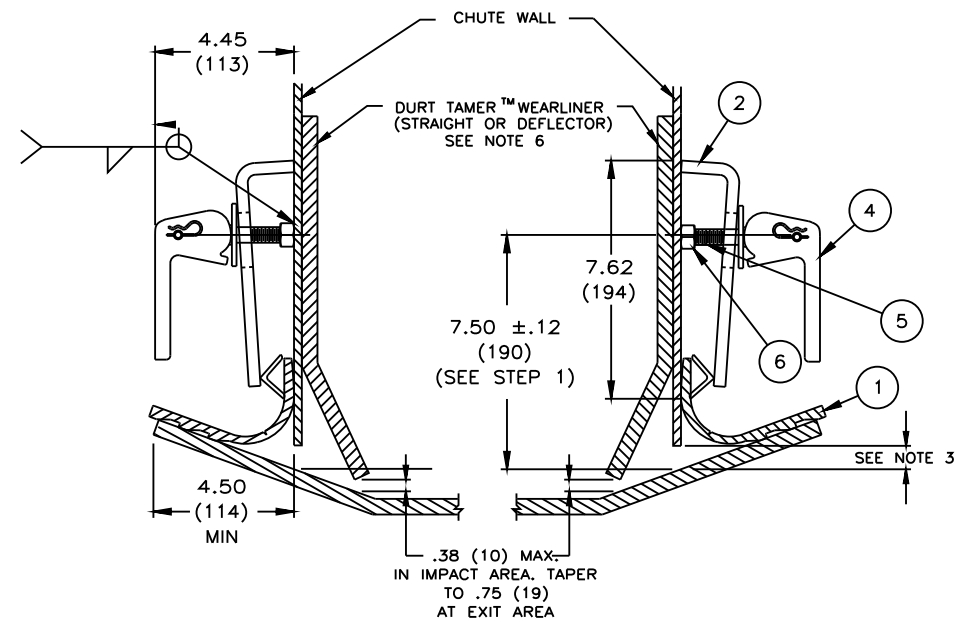

**APRON SEAL™ ON 20° BELT**

(ALL DIMENSIONS TYPICAL EACH SIDE OF CONVEYOR)

**NOTES:**

- 1) ALL DIMENSIONS ARE GIVEN IN INCHES (MM).
- 2) ALL DIMENSIONS ARE SHOWN FOR REFERENCE PURPOSES ONLY.
- 3) MARTIN RECOMMENDS CHUTE WALL BEING WITHIN .75" (19) OF BELT.
- 4) SKIRTING CAN BE ADJUSTED INDIVIDUALLY PER CLAMP TO MEET VARIATIONS IN BELT PROFILE.
- 5) A MIN. 10"(254) VERTICAL AND 4"(102) HORIZONTAL CLEARANCE REQUIRED TO INSTALL SKIRTING AND CLAMPS.
- 6) TO PROVIDE AN EFFECTIVE SEAL, WEARLINERS ARE TO BE USED TO PREVENT THE MAIN LOAD FROM CONTACTING THE SKIRTING.
- 7) WHEN WEARLINERS ARE BOLTED TO CHUTE WALL. SKIRTING AND CLAMPS ARE TO BE MOUNTED IN A MANNER AS TO ALLOW EASY ACCESS TO BOLTS.
- 8) SKIRTING IS DESIGNED TO SEAT IN QUICKLY REGARDLESS OF TROUGH ANGLE.
- 9) SKIRTING IS PLIABLE ENOUGH TO STRETCH OR BEND AROUND WEARLINER BOLTS, SKIRTING CAN ALSO BE NOTCHED OUT AROUND BOLTS IF NECESSARY.
- 10) MARTIN APRON SEAL™ SKIRTING IS DESIGNED AS A DUST SEAL. IT IS NOT DESIGNED AS A MATERIAL HOLDBACK OR LOAD CARRYING SURFACE.
- 11) CONVEYOR BELT MUST NOT LIFT OFF IDLERS DURING STARTUP OR WHILE BELT IS RUNNING.
- 12) BELT MUST TRACK PROPERLY TO PREVENT BELT FROM RUNNING BEHIND SKIRTING.
- 13) FOR INSTALLATIONS WITH UNUSUAL OR SEVERE CONDITIONS: I.E. CONCAVE/CONVEX CURVES, EXTREME SIDE PRESSURE, EXTREMELY FAST OR SLOW BELTS, TEMPERATURE EXTREMES, CORROSIVE ATMOSPHERES, ETC., CONSULT MARTIN ENGINEERING CO.
- 14) SKIRTING AND WEARLINER SHOULD BEGIN AT LEAST 12" (305) PRIOR TO INLET SIDE OF TRANSFER CHUTE WALL.
- 15) ANY DEVIATION IN MOUNTING, OTHER THAN SHOWN, CUSTOMER SHOULD CONSULT MARTIN ENGINEERING.
- 16) CLAMP IS TO BE FULLY TIGHTENED AGAINST CHUTE WALL.
- 17) CLAMP MUST HAVE FIRM BACKING TO INSURE PROPER CLAMP FORCE.
- 18) QUICK RELEASE CLAMP (P/N 36273) HANDLE CAN BE LOCKED INTO ANY ORIENTATION.

© Copyright 2002 Martin Engineering. All rights reserved. Covered by U.S. and foreign patents pending and issued. ® and TM indicate trademarks of Martin Engineering.

**MARTIN ENGINEERING**  
NEPONSET ILLINOIS USA

TITLE	INSTALLATION DRAWING FOR ANGLE & TORSION ARM CLAMP W/RUBBER APRON SEAL™ & QUICK RELEASE CLAMP	DRAWN MJB DATE 08/19/02
ENG. JAP DATE 08/20/02	CHECKED	
APPROVED JRB DATE 08/20/02		

NO.	DESCRIPTION	ECN	DATE	BY
	REVISION			

SALES DRAWING  
PR09075  
L:\SAL\S37455  
S37455  
SCALE 1/4