

ITEM	QTY.	DESCRIPTION	PART NUMBER
1	*	APRON SEAL™ 1-PIECE HEAVY DUTY	100723
2	**	ANGLE CLAMP WELDMENT	32049
3	***	QUICK RELEASE CLAMP ASSEMBLY	36273
4	***	ROD THREADED 1/2-13NC X 3	31189
5	***	NUT HEX 1/2-13NC PLAIN	34134

INSTALLATION DETAIL

ALL DIMENSIONS TYPICAL
EACH SIDE OF CONVEYOR
ON ALL LAYOUTS

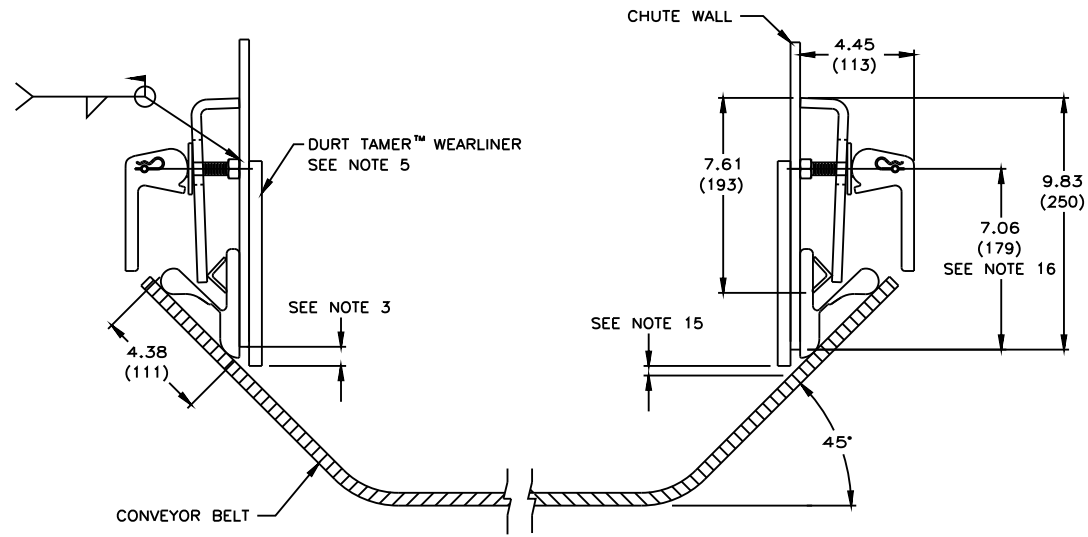

DETAIL FOR 45° BELT

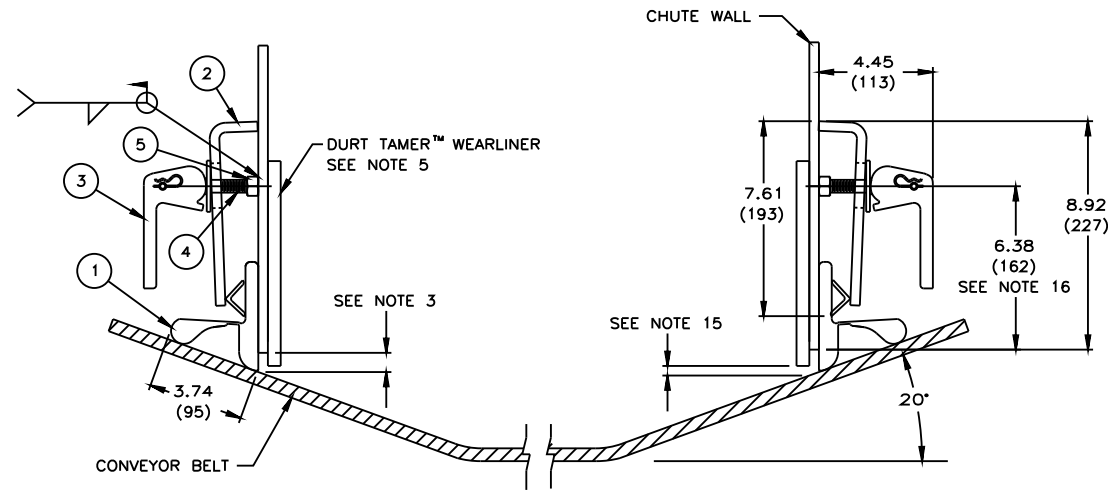

DETAIL FOR 20° BELT

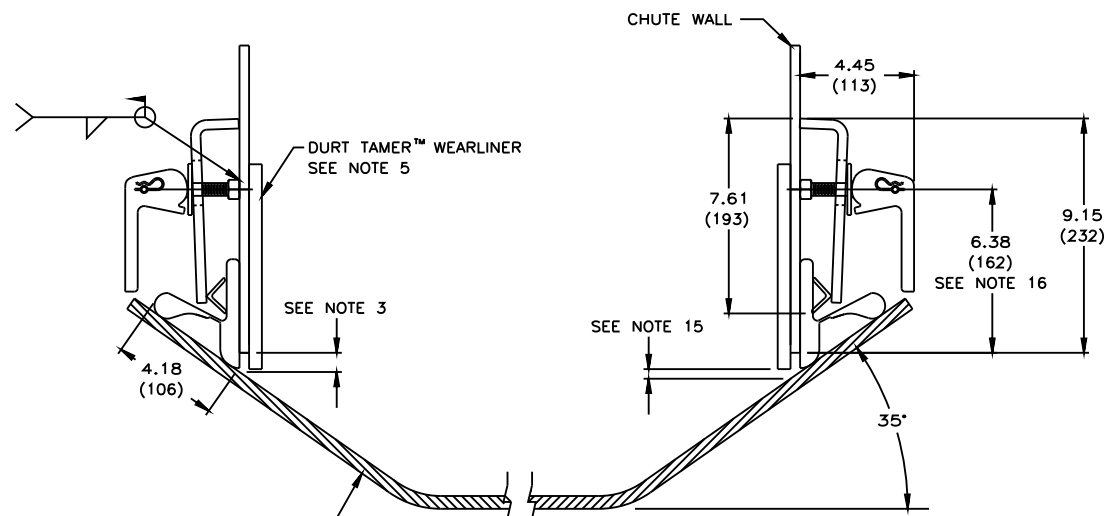

DETAIL FOR 35° BELT

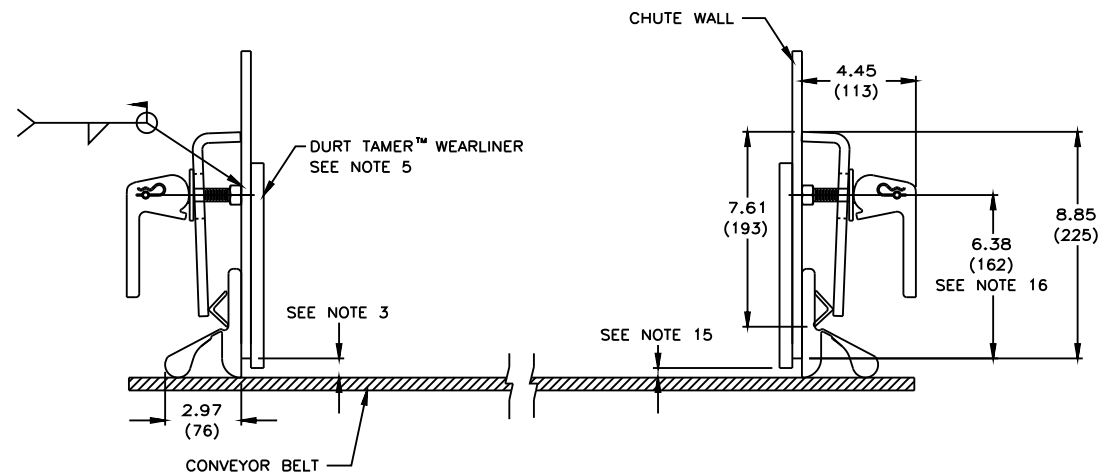

DETAIL FOR FLAT BELT

SEE NOTE 17

- * - SPECIFY LENGTH NEEDED IN FEET.
- ** - EACH WELDMENT IS 71.88(1826) LONG. (1) WELDMENT REQUIRED PER EVERY 6'-0"(1829) OF 1-PC HD APRON SEAL™ (P/N 100723).
- *** - USE ONE PER EACH FOOT OF APRON SEAL™

NOTES:

- 1) ALL DIMENSIONS ARE GIVEN IN INCHES (MM).
- 2) ALL DIMENSIONS ARE FOR REFERENCE ONLY.
- 3) MARTIN ENGINEERING RECOMMENDS CHUTE WALL TO BE WITHIN .75 (19) OF BELT.
- 4) A MIN. OF 8.00 (203) VERTICAL AND 4.00 (102) HORIZONTAL CLEARANCE REQUIRED TO INSTALL 1-PC HD APRON SEAL™ & ANGLE CLAMPS.
- 5) TO PROVIDE AN EFFECTIVE SEAL, DURT TAMER™ WEARLINERS (STRAIGHT OR DEFLECTOR) ARE RECOMMENDED TO PREVENT THE MAIN LOAD FROM CONTACTING THE 1-PC HD APRON SEAL™ (STRAIGHT WEARLINER SHOWN).
- 6) IF DURT TAMER™ WEARLINERS ARE BOLTED TO CHUTE WALL, 1-PC HD APRON SEAL™ AND ANGLE CLAMPS ARE TO BE MOUNTED IN A MANNER AS TO ALLOW EASY ACCESS TO BOLTS.
- 7) 1-PC HD APRON SEAL™ IS DESIGNED AS A DUST SEAL ONLY. IT IS NOT TO BE USED AS A MATERIAL HOLDBACK OR LOAD CARRYING SURFACE.
- 8) BELT MUST NOT LIFT OFF IDLERS DURING START-UP OR WHILE BELT IS IN OPERATION.
- 9) BELT MUST TRACK PROPERLY TO PREVENT IT FROM RUNNING BEHIND 1-PC HD APRON SEAL™
- 10) CONSULT MARTIN ENGINEERING FOR INSTALLATIONS WITH UNUSUAL OR SEVERE CONDITIONS, I.E.: CONCAVE/CONVEX CURVES, EXTREME SIDE PRESSURE, UNUSUALLY FAST OR SLOW MOVING BELTS, TEMPERATURE EXTREMES, ETC.
- 11) 1-PC HD APRON SEAL™ AND DURT TAMER™ WEARLINER SHOULD BEGIN AT LEAST 12.00 (305) BEFORE INLET SIDE OF CHUTE WALL.
- 12) CONTACT MARTIN ENGINEERING PRIOR TO MOUNTING THESE PRODUCTS IN ANY WAY OTHER THAN WHAT IS DEPICTED ON THIS DRAWING.
- 13) ANGLE CLAMP WELDMENT (P/N 32049) IS TO BE FULLY TIGHTENED AGAINST CHUTE WALL.
- 14) ANGLE CLAMP WELDMENT MUST HAVE FIRM BACKING TO ENSURE PROPER CLAMP FORCE.
- 15) .38 (10) MAX. IN IMPACT AREA, TAPERING TO .75 (19) AT EXIT AREA.
- 16) FOR FLAT TO 35° BELTS USE PRE-FAB CHUTE WALL P/N 33564-35. FOR 45° BELTS USE P/N 33564-45.
- 17) QUICK RELEASE CLAMP (P/N 36273) HANDLE CAN BE LOCKED INTO ANY ORIENTATION.

INSTALLATION INSTRUCTIONS

- STEP 1: SCRIBE A LINE PARALLEL TO BELT SURFACE 6.38 (162) ABOVE BELT. (NOTE: 45° BELT USE 7.06 (180))
- STEP 2: ALONG THIS LINE, MAKE FIRST MARK 5.88 (150) FROM END OF CHUTE WALL AND MARK EVERY 12.00 (305).
- STEP 3: ON THESE MARKED CENTERS, WELD 1/2-13NC X 3 RODS. WHEN WELDING RODS, MAKE SURE THAT THEY ARE WELDED PERPENDICULAR TO THE CHUTE WALL TO ENSURE EVEN CLAMP CONTACT.
- STEP 4: PLACE 1-PC HD APRON SEAL™ AGAINST CHUTE WALL, MAKING SURE IT IS IN CONTINUOUS CONTACT WITH BELT. PLACE ANGLE CLAMP WELDMENT OVER PREVIOUSLY WELDED STUDS.
- STEP 5: PUSH ANGLE CLAMP WELDMENT TIGHT AGAINST 1-PC HD APRON SEAL™ AND INSTALL QUICK RELEASE CLAMP.

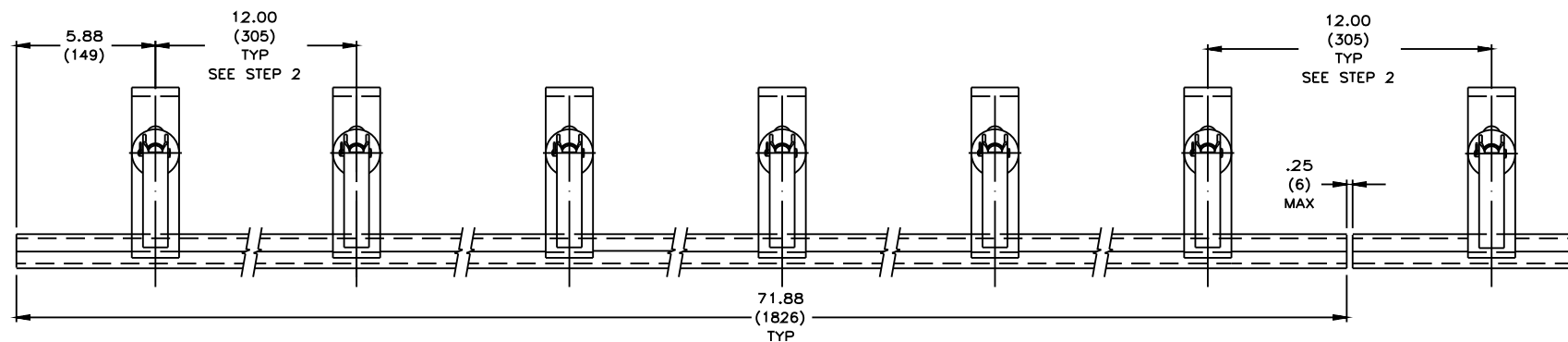

ANGLE CLAMP DETAIL

© Copyright 2002 Martin Engineering. All rights reserved. Covered by U.S. and foreign patents pending and issued. ® and ™ indicate trademarks of Martin Engineering.

MARTIN ENGINEERING
NEPONSET ILLINOIS USA

TITLE: INSTALLATION DRAWING FOR 1-PIECE HEAVY DUTY APRON SEAL™ AND QUICK RELEASE CLAMP
DRAWN: MJB DATE: 08/23/02
CHECKED: JFB
ENG. DATE: 08/26/02
APPROVED: JFB
DATE: 08/26/02

NO.	DESCRIPTION	ECN	DATE	BY	SALES DRAWING	SCALE
	REVISION				MD0562	1/4

S37464