

ASSEMBLY PART NO.	DIM "A"	DIM "B"	DIM "C"	DIM "D"	DIM "E"	BLADE QTY
DT2S2-36X30XXXX	30.00 [762]	45.00 [1143]	54.16 [1376]	67.50 [1715]	24.00 [610]	10
DT2S2-36X36XXXX	36.00 [914]	45.00 [1143]	54.16 [1376]	67.50 [1715]	24.00 [610]	12
DT2S2-42X36XXXX	36.00 [914]	51.00 [1295]	60.16 [1528]	73.50 [1867]	27.00 [686]	12
DT2S2-42X42XXXX	42.00 [1067]	51.00 [1295]	60.16 [1528]	73.50 [1867]	27.00 [686]	14
DT2S2-48X42XXXX	42.00 [1067]	57.00 [1448]	66.16 [1680]	79.50 [2019]	30.00 [762]	14
DT2S2-48X48XXXX	48.00 [1219]	57.00 [1448]	66.16 [1680]	79.50 [2019]	30.00 [762]	16
DT2S2-54X48XXXX	48.00 [1219]	63.00 [1600]	72.16 [1833]	85.50 [2172]	33.00 [838]	16
DT2S2-54X54XXXX	54.00 [1372]	63.00 [1600]	72.16 [1833]	85.50 [2172]	33.00 [838]	18
DT2S2-60X54XXXX	54.00 [1372]	69.00 [1753]	78.16 [1985]	91.50 [2324]	36.00 [914]	18
DT2S2-60X60XXXX	60.00 [1524]	69.00 [1753]	78.16 [1985]	91.50 [2324]	36.00 [914]	20
DT2S2-66X60XXXX	60.00 [1524]	75.00 [1905]	84.16 [2138]	97.50 [2477]	39.00 [991]	20
DT2S2-66X66XXXX	66.00 [1676]	75.00 [1905]	84.16 [2138]	97.50 [2477]	39.00 [991]	22
DT2S2-72X66XXXX	66.00 [1676]	81.00 [2057]	90.16 [2290]	103.50 [2629]	42.00 [1067]	22
DT2S2-72X72XXXX	72.00 [1829]	81.00 [2057]	90.16 [2290]	103.50 [2629]	42.00 [1067]	24
DT2S2-84X78XXXX	78.00 [1981]	93.00 [2362]	102.16 [2595]	115.50 [2934]	48.00 [1219]	26
DT2S2-96X90XXXX	90.00 [2286]	105.00 [2667]	114.16 [2900]	127.50 [3239]	54.00 [1372]	30

TENSIONING CHART	
BELT WIDTH	COMPRESSED SPRING LENGTH
18-24 [400-650]	1-5/8 [41]
30-48 [650-1400]	1-1/2 [38]
54-66 [1400-1800]	1-3/4 [45]
72-96 [1800-2400]	1-5/8 [41]
102-120 [2400-3000]	1-1/2 [38]

ITEM	QTY.	DESCRIPTION	PART NUMBER
1	1	DT SPLIT TRACK 2 PC SEC ASM	DT2S2-XXXXXXXS
2	1	INLINE/REV SPRING TENSIONER	37707
3	S/C	REPLACEMENT BLADE	36316-T

S/C = SEE CHART

BLADE CHART		
PART NUMBER	DESCRIPTION	BLADE P/N
DT2S2-XXAXXXXXX	INLINE TC	36316-TXX
DT2S2-XXCXXXXXX	INLINE TC W/SS HOLDER	36316-STXX

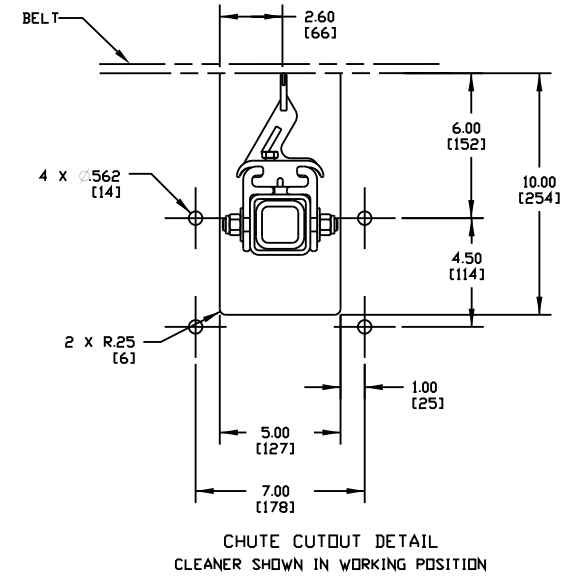
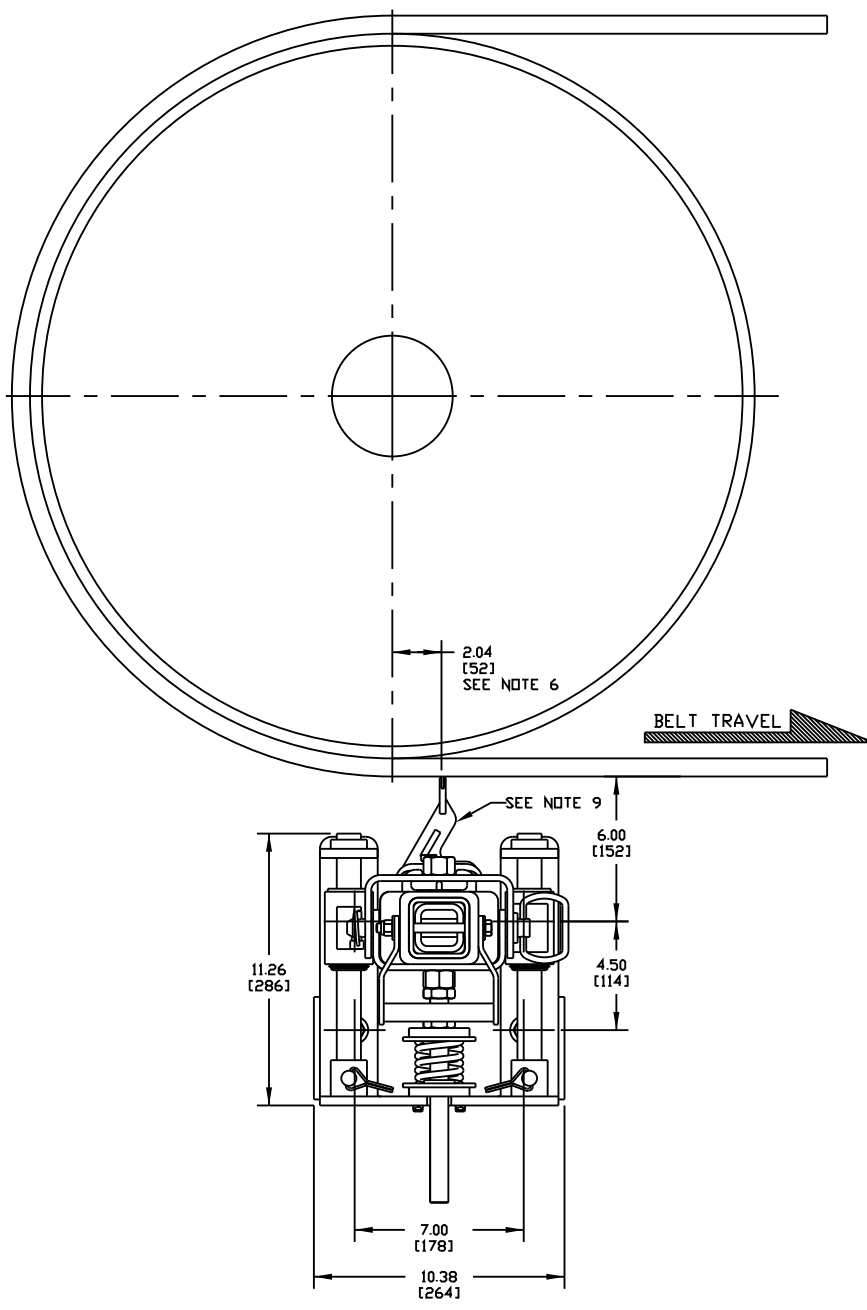

- NOTES:
- ALL DIMENSIONS ARE GIVEN IN INCHES (MM).
  - ALL DIMENSIONS ARE FOR REFERENCE PURPOSES ONLY.
  - BOLT OR WELD TENSIONER ASSEMBLY IN PLACE. BOLT TENSIONERS WHEN APPLICABLE FOR EASE OF MAINTENANCE AND ACCESSIBILITY.
  - WHERE EXTREME OR UNUSUAL CONDITIONS EXIST OR SPECIAL MAINFRAME LENGTHS ARE REQUIRED CONSULT MARTIN ENGINEERING FOR ASSISTANCE.
  - REFER TO OPERATOR'S MANUAL M3687 FOR INSTALLATION DETAILS.
  - IF INSTALLED ON CROWN PULLEY, CLEANER IS RECOMMENDED TO BE 4.00 (102) FROM THE CENTERLINE. IT IS IMPORTANT THAT THE BELT IS LEVEL. IF IT IS NOT, INCREASE DIMENSION UNTIL LEVEL.
  - CLEANER MUST BE MOUNTED WITH BLADES PERPENDICULAR TO BELT SURFACE.
  - CENTER BLADES ON BELT SURFACE.
  - THERE WILL BE APPROXIMATELY .50" GAP BETWEEN BLADE TIP AND BELT FOR UNTENSIONED SPRING.
  - THE FIRST -XX IN SUFFIX INDICATES BELT WIDTH.
    - THE NEXT X INDICATES BLADE TYPE:
      - 0 = NO BLADES
      - A = INLINE TC BLADE
      - C = INLINE TC INSERT W/SS HOLDER BLADE
      - R = TC INSERT W/SS HOLDER REVERSING BLADE
      - T = TUNGSTEN CARBIDE REVERSING BLADE
      - S = STAINLESS STEEL REVERSING BLADE
      - U = URETHANE REVERSING BLADE
    - THE NEXT XX INDICATES BLADE COVERAGE.
      - 00 = NO BLADES
    - THE NEXT XX INDICATES BLADE COLOR:
      - 00 = NO BLADES
      - BR = BROWN
      - GR = GREEN
      - OR = ORANGE
    - THE NEXT X INDICATES MAINFRAME TYPE:
      - P = STANDARD DUTY
    - THE LAST X INDICATES ACCESSORY OPTIONS:
      - 0 = NO TENSIONER
      - A = INLINE/REV AIR TENSIONER
      - S = INLINE/REV SPRING TENSIONER

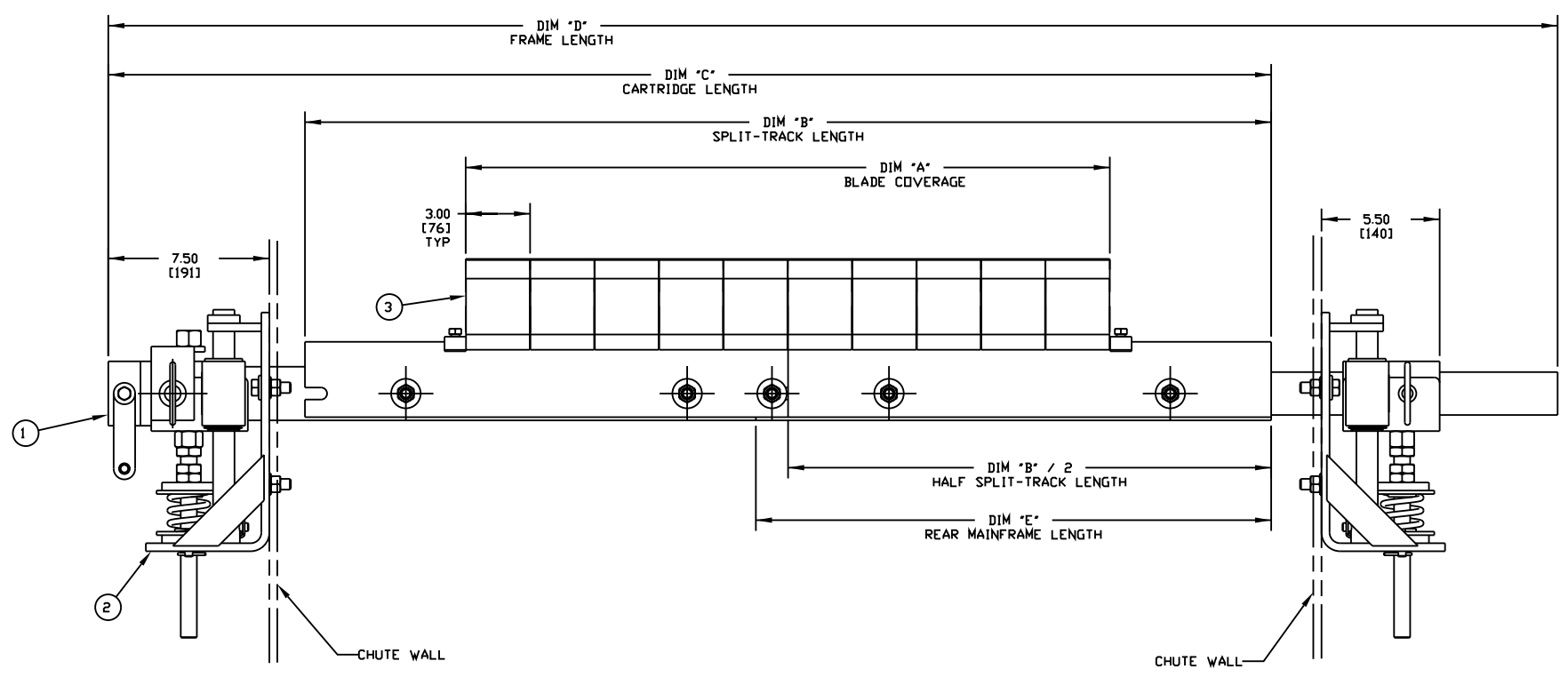

Copyright 2012 Martin Engineering. All rights reserved. Covered by U.S. and Foreign patents pending and issued. R and TM indicate trademarks of Martin Engineering.

MARTIN ENGINEERING-USA  
NEPONSET, IL USA

TITLE: MARTIN DT2S2 SEC ASM W/INLINE BLADES & INLINE/REV SPRING TENS

DRAWN: RND  
DATE: 06/03/11  
CHECKED: MJB  
DATE: 06/07/11  
APPROVED: DM  
DATE: 06/09/11  
SCALE: 1/4

NO.	DESCRIPTION	ECN	DATE	BY
	REVISION			

SALES DRAWING  
PRI2051 S50017-2-IS