

ITEM	QTY.	DESCRIPTION	PART NUMBER
1	*	MARTIN ® BDCD™ "L" STYLE SKIRTING	38199
2	**	MARTIN ® SHORT BDCD™ SKIRTING ASM	37911

\* - SPECIFY LENGTH REQUIRED IN FEET.  
 \*\* - SKIRTING ASSEMBLIES ARE 4'-0" (1219) LONG.

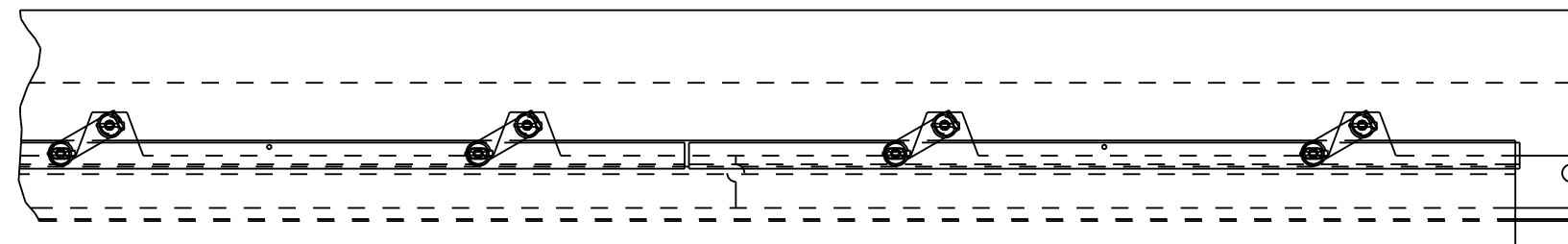

37911 SHOWN IN WORKING POSITION  
 BELT NOT SHOWN FOR CLARITY

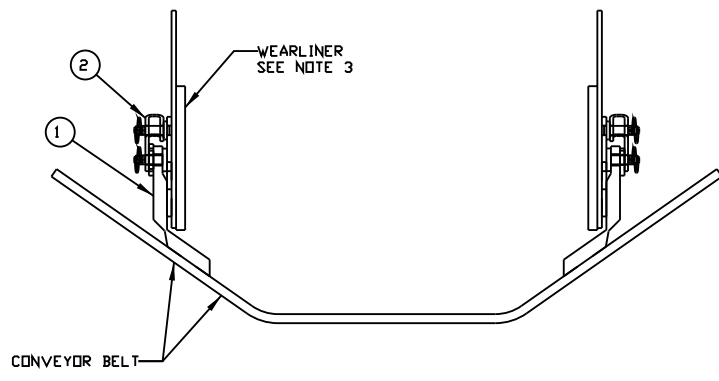
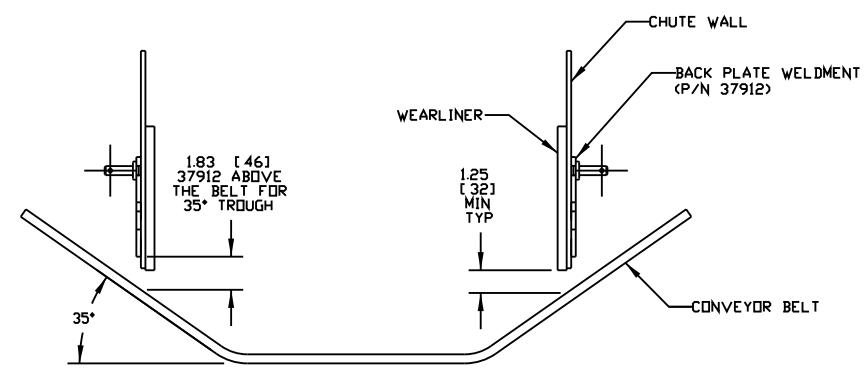

35° BELT LAYOUT  
 SCALE 3/16

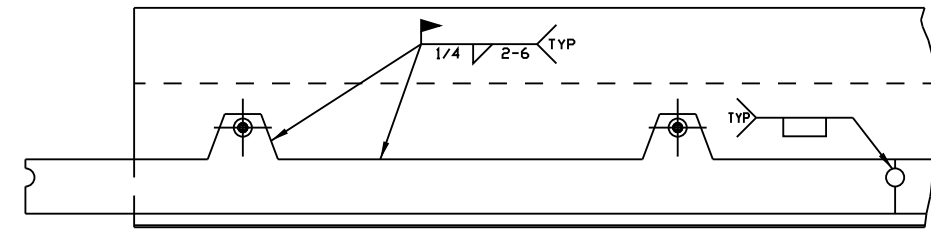

WELD DETAIL  
 BELT NOT SHOWN FOR CLARITY

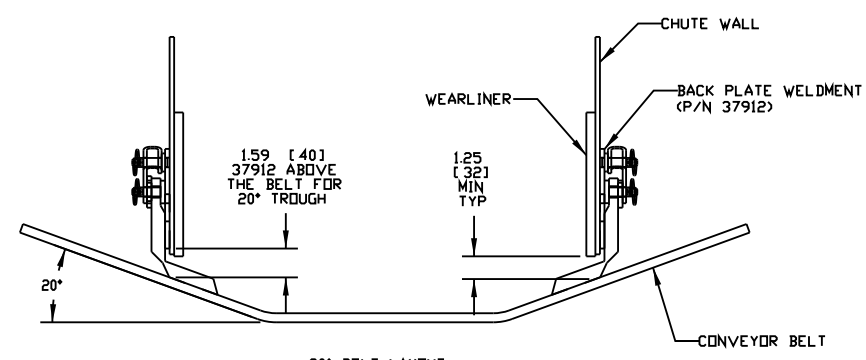

20° BELT LAYOUT  
 SCALE 3/16

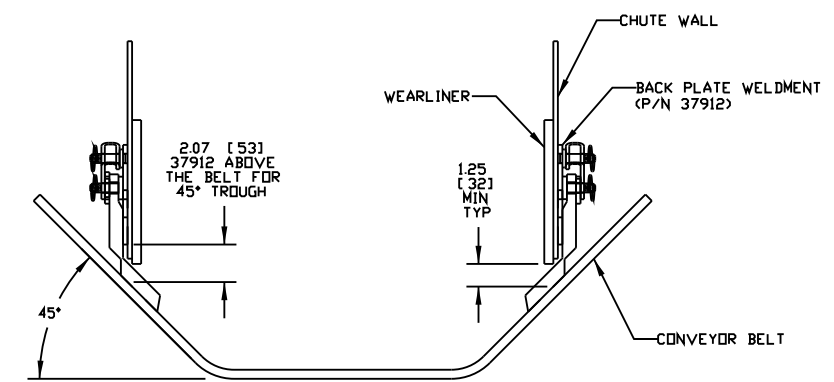

45° BELT LAYOUT  
 SCALE 3/16

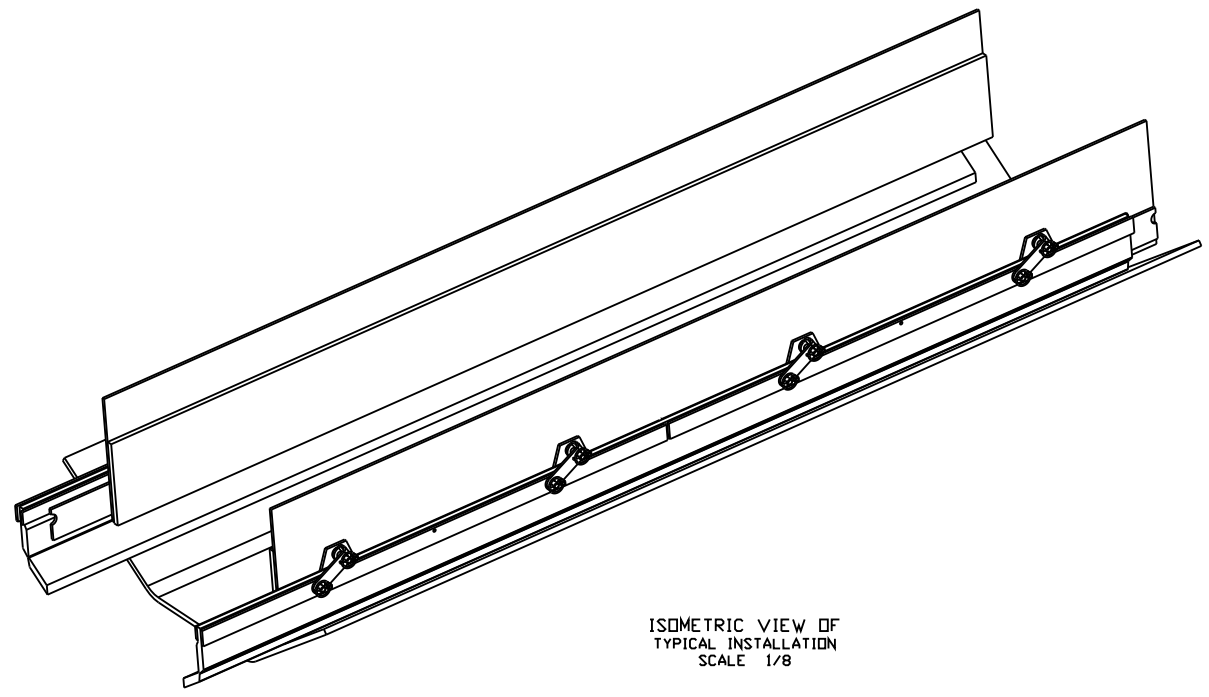

ISOMETRIC VIEW OF  
 TYPICAL INSTALLATION  
 SCALE 1/8

INSTALLATION NOTES:  
 1) LOWER 6.50 (165) OF OUTSIDE SURFACE OF CHUTE WALL MUST BE SMOOTH TO PROPERLY INSTALL THIS EQUIPMENT.  
 2) ASSEMBLE RUBBER SKIRTING (P/N 38199) BETWEEN MOUNT WELDMENT (P/N 37915) AND CLAMPING PLATE (P/N 37916) THROUGH STUDS ON MOUNT WELDMENT. LOWER FLOATING EDGE ON TO THE BELT. THIS ASSEMBLY OF COMPONENTS WILL THEN BE ATTACHED TO PRESSURE ARMS (P/N 37917-P), FROM BEHIND, BY INSERTING STUDS INTO VACANT HOLES IN PRESSURE ARMS. PIN IN PLACE USING LYNCH PINS (P/N 37111)

NOTE:  
 1) ALL DIMENSIONS IN INCHES(MM) AND ARE FOR REFERENCE ONLY.  
 2) A MINIMUM OF 7.00 (178) VERTICALLY AND 2.25 (57) HORIZONTALLY IS THE CLEARANCE REQUIRED TO INSTALL SKIRTING ASSEMBLY.  
 3) TO PROVIDE AN EFFECTIVE SEAL, DIRT TAMER WEARLINERS ARE RECOMMENDED.  
 4) CONSULT MARTIN ENGINEERING FOR INSTALLATIONS WITH UNUSUAL OR SEVERE CONDITIONS, SUCH AS: CONCAVE/CONVEX CURVES, EXTREME SIDE PRESSURE, UNUSUALLY FAST OR SLOW MOVING BELTS, TEMPERATURE EXTREMES, ETC.  
 5) SKIRTING SHOULD BEGIN AT LEAST 6.00 (305) AFTER EXIT SIDE OF CHUTE WALL.  
 6) REFER TO OPERATOR'S MANUAL M3612 DURING INSTALLATION. THIS DRAWING IS NOT TO BE USED IN PLACE OF THE OPERATOR'S MANUAL.  
 7) CONTACT MARTIN ENGINEERING PRIOR TO INSTALLING THIS EQUIPMENT IN ANY WAY OTHER THAN WHAT IS SHOWN ON THIS DRAWING OR IN THE OPERATOR'S MANUAL (M3612).

NO.	DESCRIPTION	ECN	DATE	BY	SALES DRAWING
	REVISION				

Copyright 2007 Martin Engineering. All rights reserved. Covered by U.S. and Foreign patents pending and issued. R and TM indicate trademarks of Martin Engineering.

**MARTIN ENGINEERING**  
 NEPONSET ILLINOIS USA

TITLE	MARTIN® BDCD™ "L" STYLE SKIRTING INSTALLATION DRAWING	DRAWN	RND
DATE	08/09/07	CHECKED	
ENG.	MJB	DATE	08/23/07
APPROVED	TJG	DATE	08/27/07
SCALE	3/16		

SALES DRAWING  
 PRI0836 S50026-L