

ITEM	QTY.	DESCRIPTION	PART NUMBER
1	1	MARTIN QC #1 XHD DUAL BLADE ASM	SEE CHART
2	1	MARTIN XHD DUAL SPRING TENSIONER	38003-2
3	2	MARTIN LOW PROFILE ACCESS DOOR	CYA-1218

MOUNTING LOCATION CHART	
DIM "C"	DIM "D"
HEAD PULLEY DIAMETER *	
16 [400]	5.75 [146]
20 [500]	5.50 [140]
24 [600]	5.25 [133]
28 [700]	5.00 [127]
30-120 [750-3000]	4.75 [120]

\* INCLUDES BELT AND LAGGING

ASSEMBLY PART NO.	COLOR
35899DXXXXXX	ORANGE
35899DXXXXXXBRX	BROWN
35899DXXXXXXCLX	TAN
35899DXXXXXXGRX	GREEN
35899DXXXXXXNBX	NAVY BLUE
35899DXXXXXXYLX	YELLOW

PART NO.	BELT WIDTH	DIM "A" MAX BLADE COVERAGE	DIM "B" FRAME LENGTH
35899D54X148XXX	54.00 [1350-1400]	48.00 [1219]	102.00 [2591]
35899D60X154XXX	60.00 [1500]	54.00 [1372]	108.00 [2743]
35899D72X066XXX	72.00 [1800]	66.00 [1676]	120.00 [3048]
35899D72X166XXX	72.00 [1800]	66.00 [1676]	120.00 [3048]
35899D78X072XXX	78.00 [2000]	72.00 [1829]	126.00 [3200]
35899D78X172XXX	78.00 [2000]	72.00 [1829]	126.00 [3200]
35899D84X072XXX	84.00 [2200]	72.00 [1829]	132.00 [3353]
35899D84X078XXX	84.00 [2200]	78.00 [1981]	132.00 [3353]
35899D84X172XXX	84.00 [2200]	72.00 [1829]	132.00 [3353]
35899D84X178XXX	84.00 [2200]	78.00 [1981]	132.00 [3353]
35899D96X084XXX	96.00 [2400-2500]	84.00 [2134]	144.00 [3658]
35899D96X090X1X	96.00 [2400-2500]	90.00 [2286]	144.00 [3658]
35899D96X184XXX	96.00 [2400-2500]	84.00 [2134]	144.00 [3658]
35899D96X190XXX	96.00 [2400-2500]	90.00 [2286]	144.00 [3658]
35899D102X096XXX	102.00 [2600]	96.00 [2438]	150.00 [3810]
35899D102X196XXX	102.00 [2600]	96.00 [2438]	150.00 [3810]
35899D108X0102XXX	108.00 [2800]	102.00 [2591]	156.00 [3962]
35899D114X0108XXX	114.00 [2900]	108.00 [2743]	168.00 [4267]
35899D114X1108XXX	114.00 [2900]	108.00 [2743]	168.00 [4267]
35899D120X0114XXX	120.00 [3000]	114.00 [2896]	168.00 [4267]
35899D120X1114XXX	120.00 [3000]	114.00 [2896]	168.00 [4267]

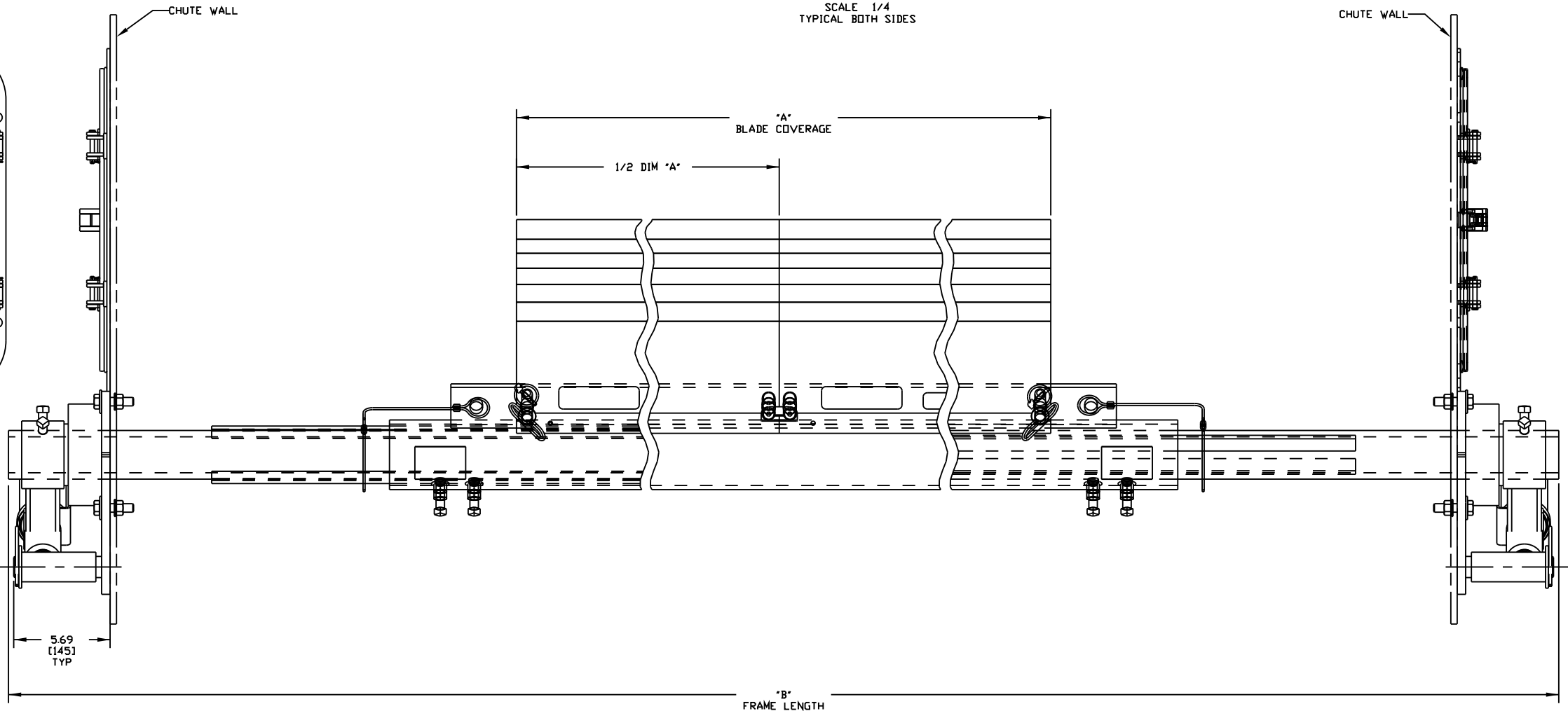
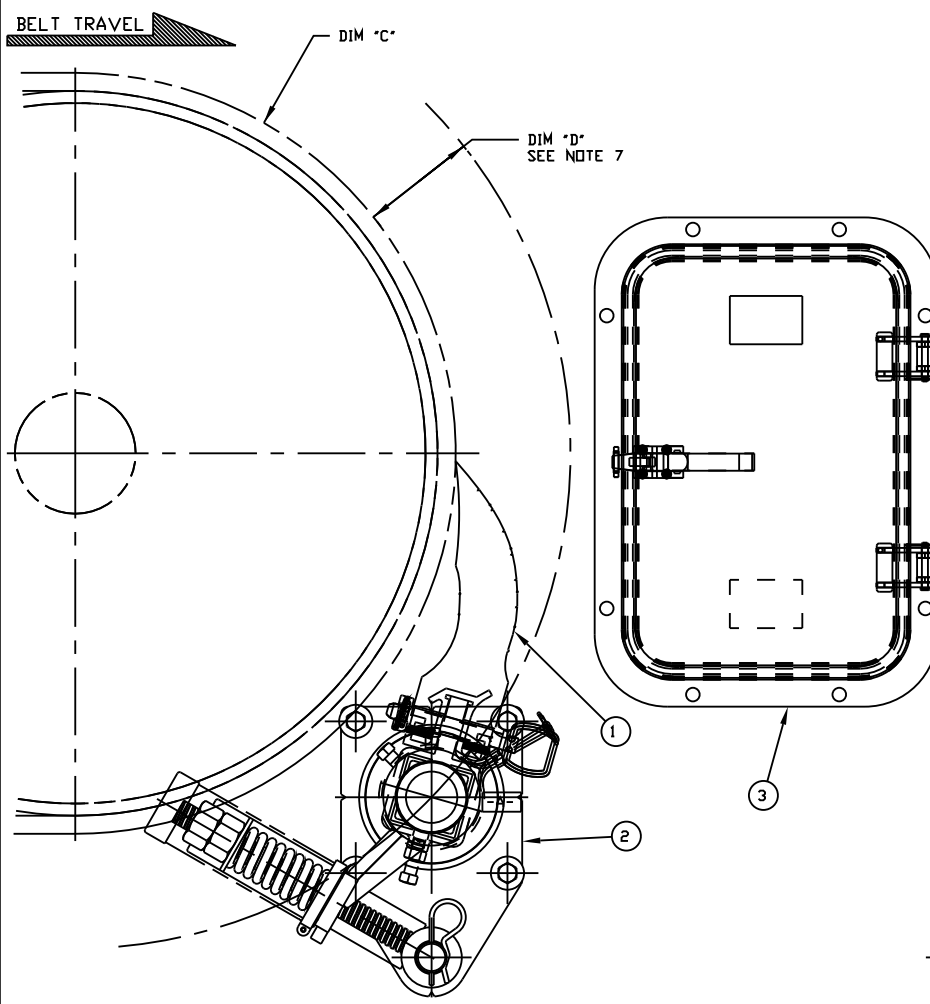
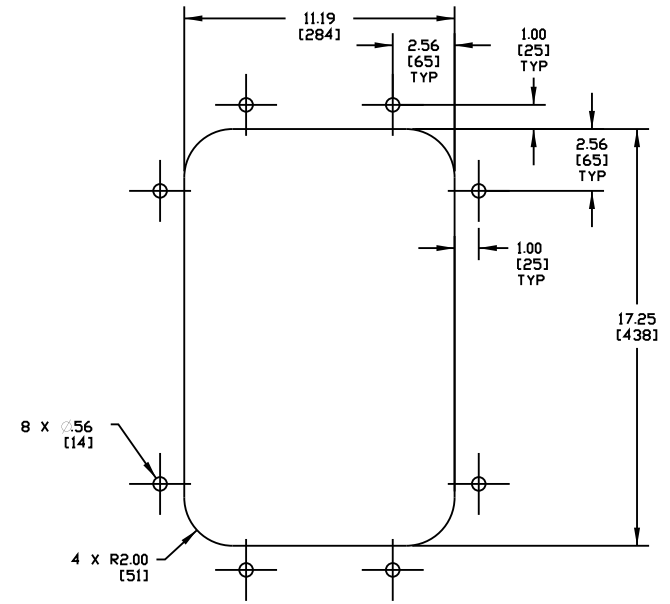
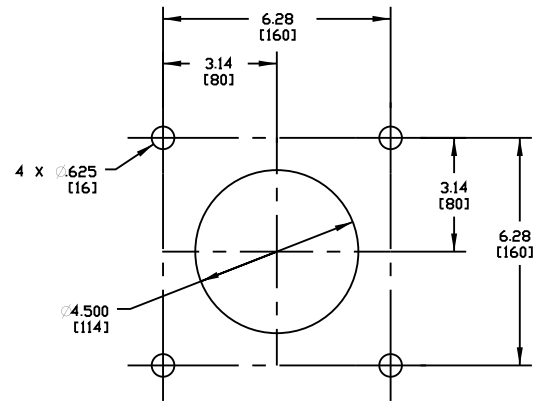

- NOTES:
- 1) ALL DIMENSIONS ARE GIVEN IN INCHES [MM].
  - 2) ALL DIMENSIONS ARE FOR REFERENCE ONLY.
  - 3) FOR EASY ACCESSIBILITY AND MAINTENANCE, MARTIN ENGINEERING RECOMMENDS BOLTING CLEANER TO EXISTING STRUCTURE WHEN APPLICABLE.
  - 4) CLEANER IS SHOWN IN RECOMMENDED WORKING POSITION.
  - 5) WHERE EXTREME OR UNUSUAL CONDITIONS EXIST, OR SPECIAL MAINFRAME LENGTHS ARE REQUIRED CONTACT MARTIN ENGINEERING.
  - 6) REFER TO OPERATOR'S MANUALS M3504, & M3127 FOR COMPLETE INSTALLATION INSTRUCTIONS.
  - 7) CLEANER CAN BE LOCATED ANYWHERE ALONG THE ARC, AS LONG AS THE MAINFRAME IS OUT OF MATERIAL TRAJECTORY AND THE BLADE TIPS ARE BELOW THE HORIZONTAL CENTERLINE OF THE HEAD PULLEY.
  - 8) THE XHD QC #1 PRE-CLEANER BLADES ARE DESIGNED TO REMOVE HEAVY CARRYBACK ONLY. DO NOT OVERTENSION.
  - 9) ONE FULL TURN OF THE TENSIONING NUT ON THE SPRING TENSIONER IS EQUAL TO .20 [5].
  - 10) BLADE COVERAGE IS LESS THAN BELT WIDTH, DUE TO POSSIBLE MISTRACKING OR DAMAGED EDGES OF THE BELT.
  - 11) THE FIRST TWO XX'S OF THE CLEANER PART NUMBER INDICATE BELT WIDTH. THE THIRD X INDICATES SOLID (1) OR SLIT (0). THE FOURTH X INDICATES SOLID (1) OR SEGMENTED (0). THE NEXT TWO XX'S INDICATE BLADE WIDTH. THE LAST TWO XX'S INDICATE BLADE COLOR/MATERIAL. EXAMPLE: 35899D541148BR (54.00 BELT WIDTH, 48.00 SOLID, DUAL BROWN BLADE).

Copyright 2013 Martin Engineering. All rights reserved. Covered by U.S. and Foreign patents pending and issued. R and TM indicate trademarks of Martin Engineering.

MARTIN ENGINEERING-USA  
NEPONSET, IL USA

TITLE	MARTIN QC #1 XHD DUAL BLD PRE-CLEANER W/XHD DUAL SPRING TENS & 12X18 ACCESS DOOR	DRAWN	RND
DATE	02/03/11	CHECKED	
ENG.	MJB	DATE	02/03/11
APPROVED DM		DATE	02/03/11
SCALE	1/4		

A	UPDATED MILLIMETER DIMENSIONS FOR DIM "A"	13161	09/06/11	RND
NO.	DESCRIPTION	ECN	DATE	BY
	REVISION			

SALES DRAWING  
M00819 S50033D-D