

ASSEMBLY PART NO.	DIM 'A'	DIM 'B'	DIM 'C'	DIM 'D'	BLADE QTY	TENS COMPRESSED SPRING HEIGHT	TENSIONER NO. OF FULL TURNS
DT2H-18X12XXXX	12.00 [305]	27.00 [686]	36.16 [918]	49.50 [1257]	2	2.25 [57]	1
DT2H-18X18XXXX	18.00 [457]	27.00 [686]	36.16 [918]	49.50 [1257]	3	2.25 [57]	1
DT2H-24X18XXXX	18.00 [457]	33.00 [838]	42.16 [1071]	55.50 [1410]	3	2.13 [54]	2
DT2H-24X24XXXX	24.00 [610]	33.00 [838]	42.16 [1071]	55.50 [1410]	4	2.13 [54]	2
DT2H-30X24XXXX	24.00 [610]	39.00 [991]	48.16 [1223]	61.50 [1562]	4	2.13 [54]	2
DT2H-30X30XXXX	30.00 [762]	39.00 [991]	48.16 [1223]	61.50 [1562]	5	2.13 [54]	2
DT2H-36X30XXXX	30.00 [762]	45.00 [1143]	54.16 [1376]	67.50 [1715]	5	2.00 [51]	3
DT2H-36X36XXXX	36.00 [914]	45.00 [1143]	54.16 [1376]	67.50 [1715]	6	2.00 [51]	3
DT2H-42X36XXXX	36.00 [914]	51.00 [1295]	60.16 [1528]	73.50 [1867]	6	2.00 [51]	3
DT2H-42X42XXXX	42.00 [1067]	51.00 [1295]	60.16 [1528]	73.50 [1867]	7	2.00 [51]	3
DT2H-48X42XXXX	42.00 [1067]	57.00 [1448]	66.16 [1680]	79.50 [2019]	7	1.88 [48]	4
DT2H-48X48XXXX	48.00 [1219]	57.00 [1448]	66.16 [1680]	79.50 [2019]	8	1.88 [48]	4
DT2H-54X48XXXX	48.00 [1219]	63.00 [1600]	72.16 [1833]	85.50 [2172]	8	2.25 [57]	1
DT2H-54X54XXXX	54.00 [1372]	63.00 [1600]	72.16 [1833]	85.50 [2172]	9	2.25 [57]	1
DT2H-60X54XXXX	54.00 [1372]	69.00 [1753]	78.16 [1985]	91.50 [2324]	9	2.13 [54]	2
DT2H-60X60XXXX	60.00 [1524]	69.00 [1753]	78.16 [1985]	91.50 [2324]	10	2.13 [54]	2
DT2H-66X60XXXX	60.00 [1524]	75.00 [1905]	84.16 [2138]	97.50 [2477]	10	2.13 [54]	2
DT2H-66X66XXXX	66.00 [1676]	75.00 [1905]	84.16 [2138]	97.50 [2477]	11	2.13 [54]	2
DT2H-72X66XXXX	66.00 [1676]	81.00 [2057]	90.16 [2290]	103.50 [2629]	11	2.13 [54]	2
DT2H-84X78XXXX	78.00 [1981]	93.00 [2362]	102.16 [2595]	115.50 [2934]	13	2.13 [54]	2
DT2H-96X90XXXX	90.00 [2286]	105.00 [2667]	114.16 [2900]	127.50 [3239]	15	2.00 [51]	3

ASSEMBLY PART NO	BLADE TYPE	BLADE PART NO
DT2H-XXAXXXXX	INLINE TC	36937-1

TENSIONER PART NO.	BELT WIDTHS
37806	18.00-48.00 [457-1219]
37806-1	54.00-96.00 [1372-2438]

ITEM	QTY.	DESCRIPTION	PART NUMBER
1	1	DT2H SPLIT TRACK SECONDARY ASM	DT2H-XXXXXXXX
2	1	XHD INLINE/REV SPRING TENSIONER	SEE CHART
3	S/C	REPLACEMENT INLINE BLADE	SEE CHART
4	1	RUBBER ACCESS DOOR 12.00 X 18.00	CYAR-1218
5	1	'Z' BRACKET ASM FOR DT2H CLNR	38032-01

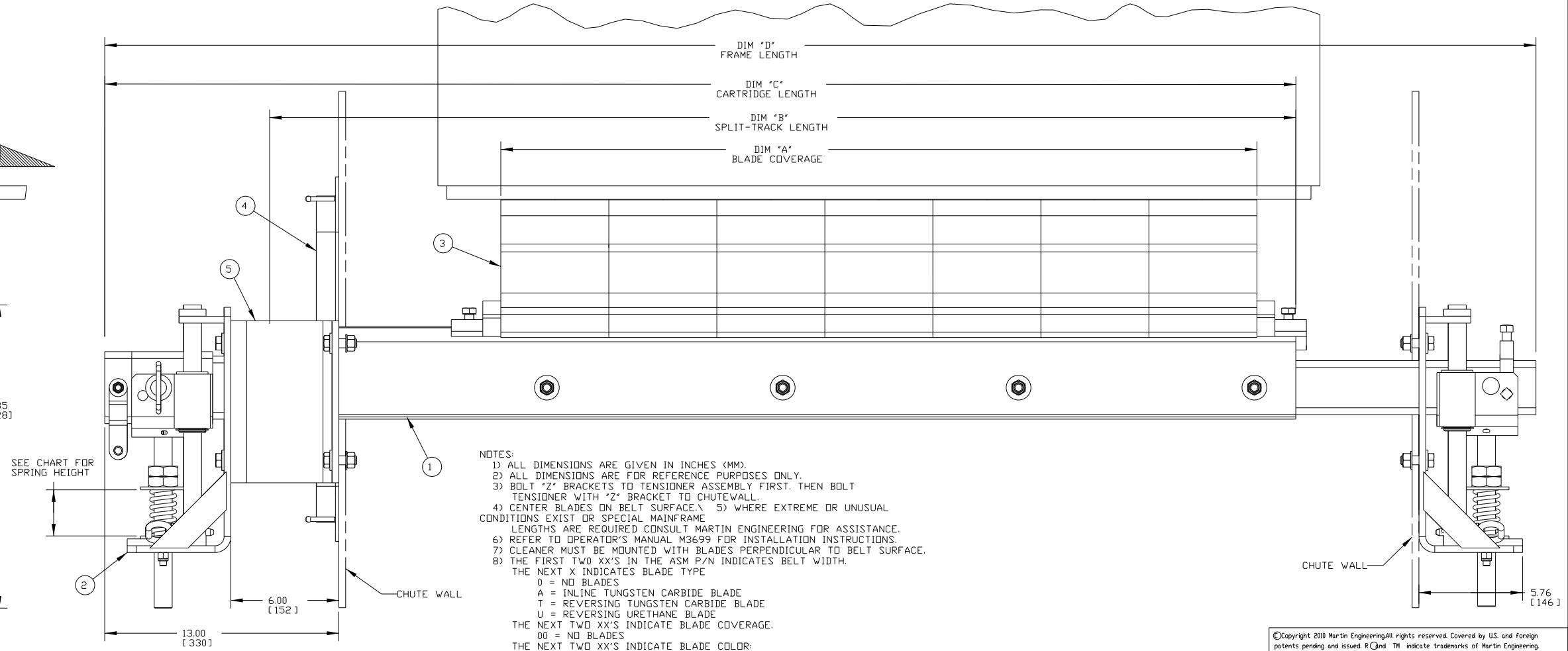
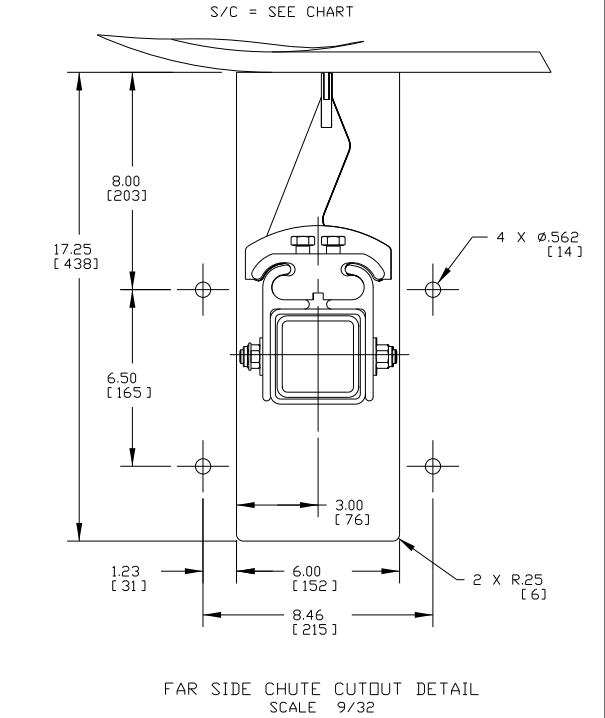
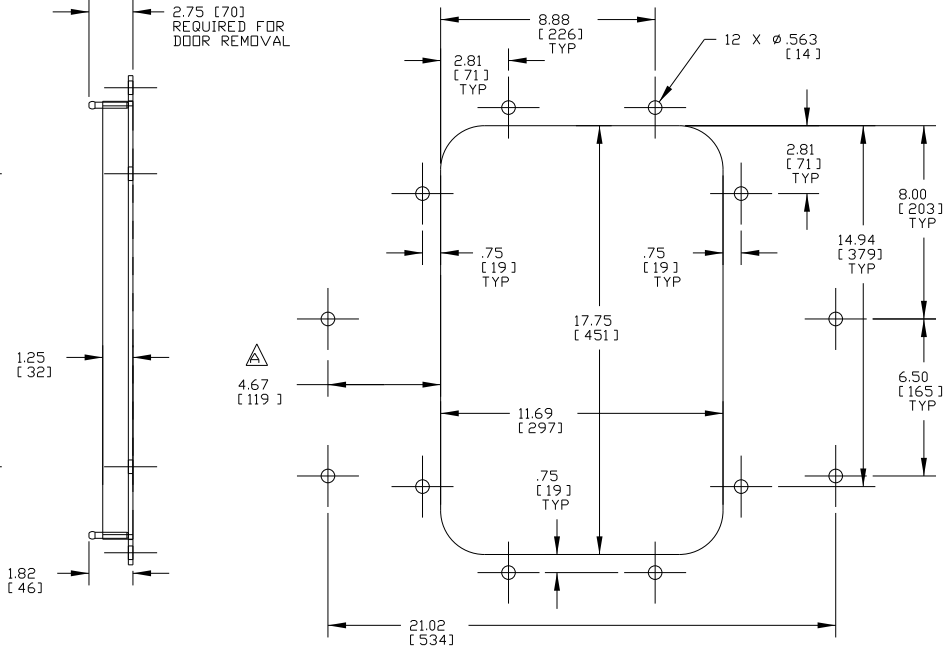
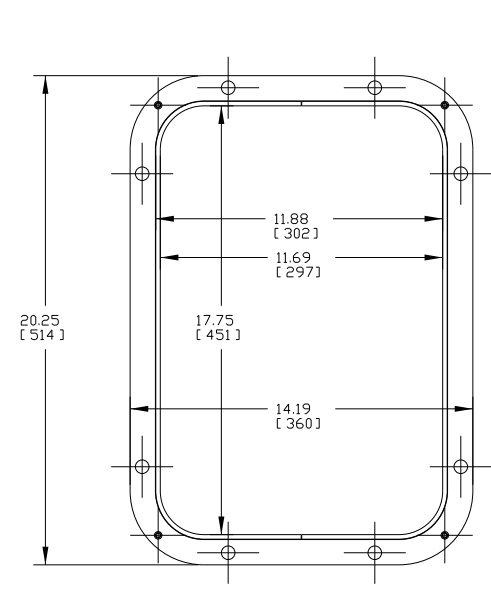
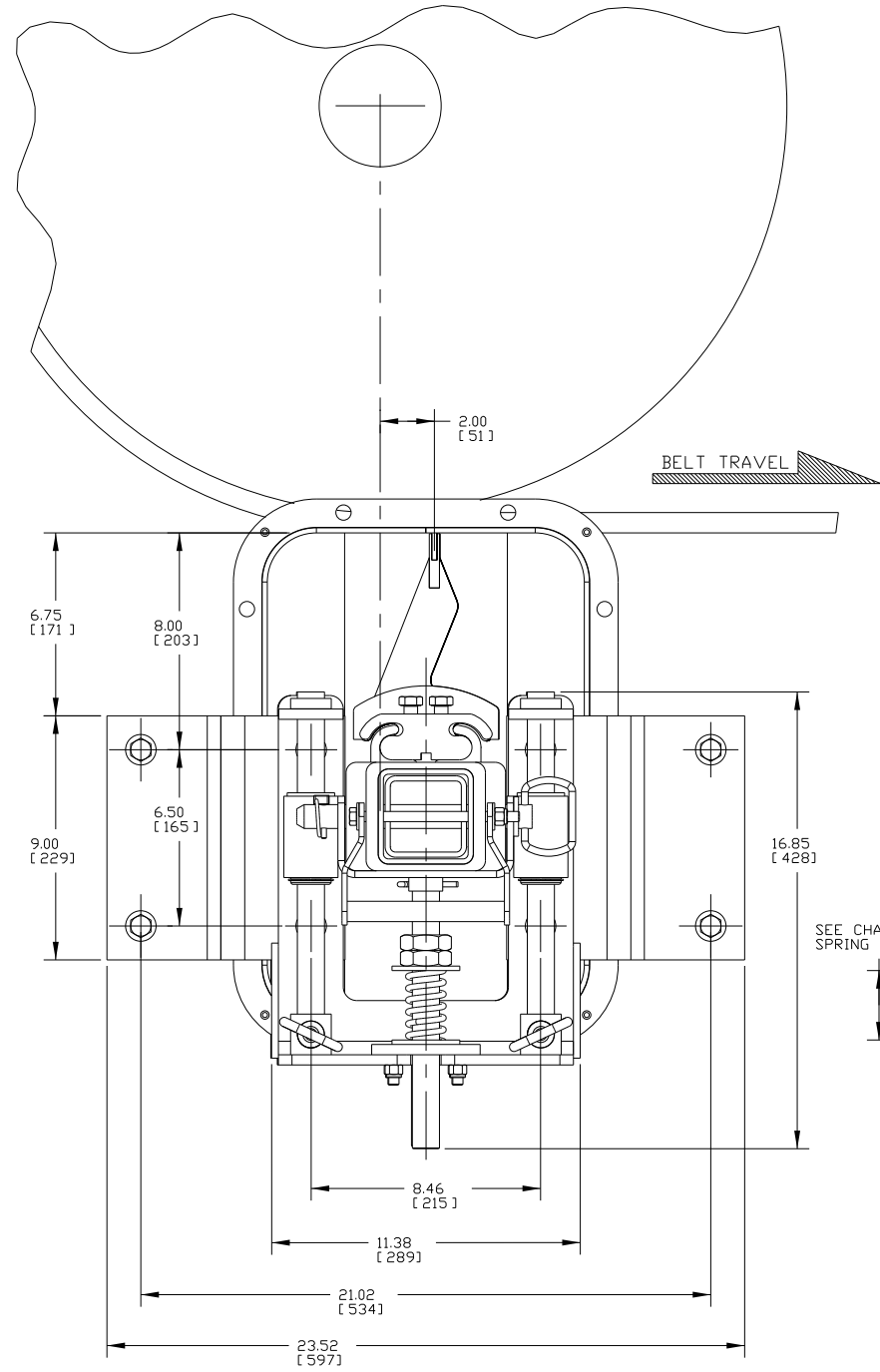

- NOTES:
- 1) ALL DIMENSIONS ARE GIVEN IN INCHES (MM).
 - 2) ALL DIMENSIONS ARE FOR REFERENCE PURPOSES ONLY.
 - 3) BOLT 'Z' BRACKETS TO TENSIONER ASSEMBLY FIRST. THEN BOLT TENSIONER WITH 'Z' BRACKET TO CHUTEWALL.
 - 4) CENTER BLADES ON BELT SURFACE. 5) WHERE EXTREME OR UNUSUAL CONDITIONS EXIST OR SPECIAL MAINFRAME LENGTHS ARE REQUIRED CONSULT MARTIN ENGINEERING FOR ASSISTANCE.
 - 6) REFER TO OPERATOR'S MANUAL M3699 FOR INSTALLATION INSTRUCTIONS.
 - 7) CLEANER MUST BE MOUNTED WITH BLADES PERPENDICULAR TO BELT SURFACE.
 - 8) THE FIRST TWO XX'S IN THE ASM P/N INDICATES BELT WIDTH. THE NEXT X INDICATES BLADE TYPE
 0 = NO BLADES
 A = INLINE TUNGSTEN CARBIDE BLADE
 T = REVERSING TUNGSTEN CARBIDE BLADE
 U = REVERSING URETHANE BLADE
 THE NEXT TWO XX'S INDICATE BLADE COVERAGE.
 00 = NO BLADES
 THE NEXT TWO XX'S INDICATE BLADE COLOR:
 00 = NO BLADES
 BR = BRDWN
 GR = GREEN
 OR = ORANGE
 NB = NAVY BLUE
 THE NEXT X INDICATES MAINFRAME TYPE:
 P = PAINTED
 THE LAST X INDICATES ACCESSORY OPTIONS:
 0 = NO TENSIONER
 A = HEAVY DUTY INLINE/REV AIR TENSIONER
 S = HEAVY DUTY INLINE/REV SPRING TENSIONER

Copyright 2010 Martin Engineering. All rights reserved. Covered by U.S. and Foreign patents pending and issued. R and TM indicate trademarks of Martin Engineering.

MARTIN ENGINEERING NEPONSET ILLINOIS USA

TITLE	DT2H DURT TRACKER [®] SPLIT-TRACK SEC ASM W/INLINE BLD/SPR TENS	DRAWN	RND
DATE	07/06/06	CHECKED	JLD
NO.	DESCRIPTION	ECN	DATE
NO.	DESCRIPTION	ECN	DATE

SALES DRAWING
 APPROVED JMM
 DATE 07/07/06
 SCALE 9/32

NO.	DESCRIPTION	ECN	DATE	BY
B	CHGD P/N FROM 27658-1218 TO CYAR-1218 IN BOM	12561	04/06/10	MJB
A	CHGD DIM FROM 3.92 TO 4.67	-	07/12/06	RND