

PART NO.	BELT WIDTH	DIM "A" FRAME LENGTH	DIM "B" BLADE COVERAGE	P/N ITEM 2
36287-24XXXXXX	24.00 [500-650]	62.00 [1575]	18.00 [457]	35392-ZHD
36287-30XXXXXX	30.00 [650-800]	68.00 [1727]	24.00 [610]	35392-ZHD
36287-36XXXXXX	36.00 [800-1000]	74.00 [1880]	30.00 [762]	35392-ZHD
36287-42XXXXXX	42.00 [1000-1200]	80.00 [2032]	36.00 [914]	35392-ZHD
36287-48XXXXXX	48.00 [1200-1400]	86.00 [2184]	42.00 [1067]	35392-2ZHD
36287-54XXXXXX	54.00 [1400-1600]	92.00 [2337]	48.00 [1219]	35392-2ZHD
36287-60XXXXXX	60.00 [1600-1800]	98.00 [2489]	54.00 [1372]	35392-2ZHD
36287-66XXXXXX	66.00 [1600-1800]	104.00 [2642]	60.00 [1524]	35392-2ZHD
36287-72XXXXXX	72.00 [1800-2000]	110.00 [2794]	66.00 [1676]	35392-2ZHD
36287-84XXXXXX	84.00 [2000-2200]	122.00 [3099]	78.00 [1981]	35392-2ZHD
36287-96XXXXXX	96.00 [2200-2400]	134.00 [3404]	90.00 [2286]	35392-2ZHD

ASSEMBLY PART NO.	COLOR
36287-XXXXXX	ORANGE
36287-XXXXXX	BROWN
36287-XXXXXX	GREEN
36287-XXXXXX	NAVY BLUE
36287-XXXXXX	TAN

ITEM	QTY.	DESCRIPTION	PART NUMBER
1	1	ZHD #800 PRE-CLEANER ASM	36287-XXXXXX
2	1	ZHD # SPRING TENSIONER ASM	SEE CHART
3	*	STEEL ACCESS DOOR 12 X 18	CYA-1218

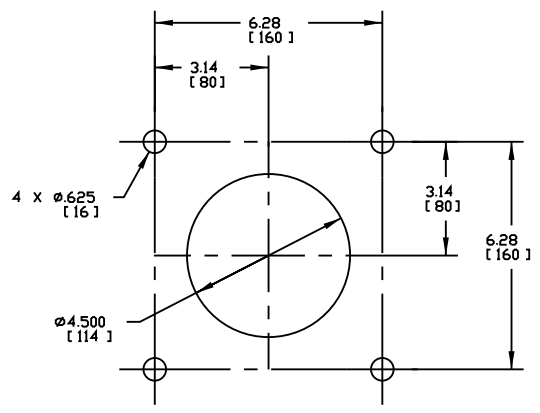

TENSIONER CHUTE CUTOUT DETAIL  
SCALE 3/8  
TYPICAL BOTH SIDES

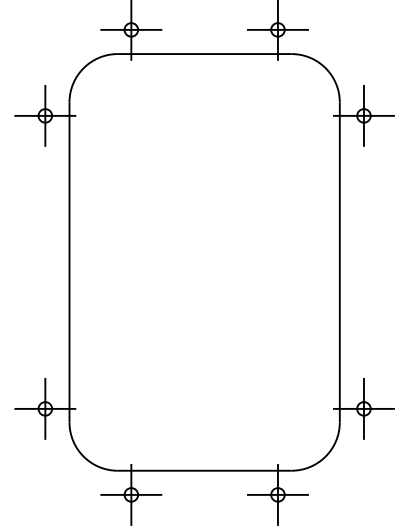

ACCESS DOOR CHUTE CUTOUT DETAIL  
SCALE 1/4

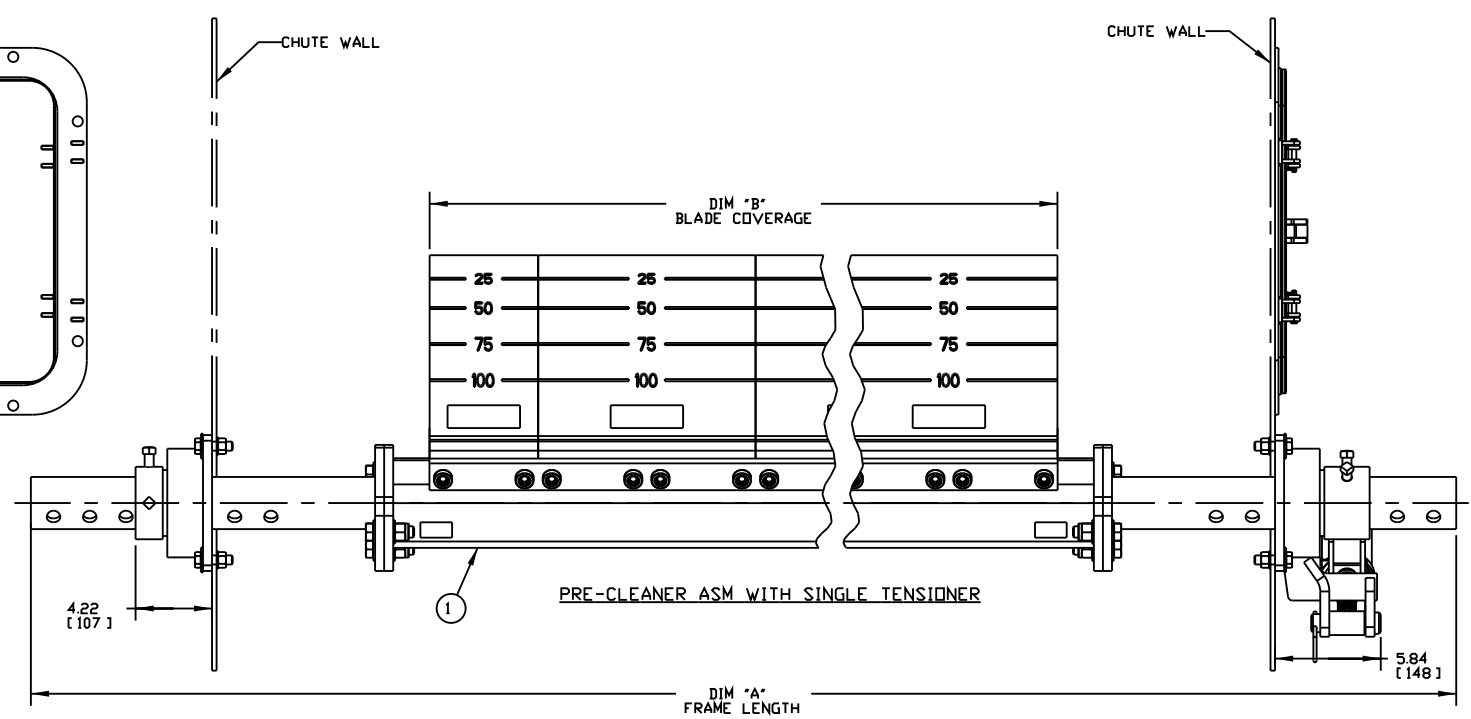
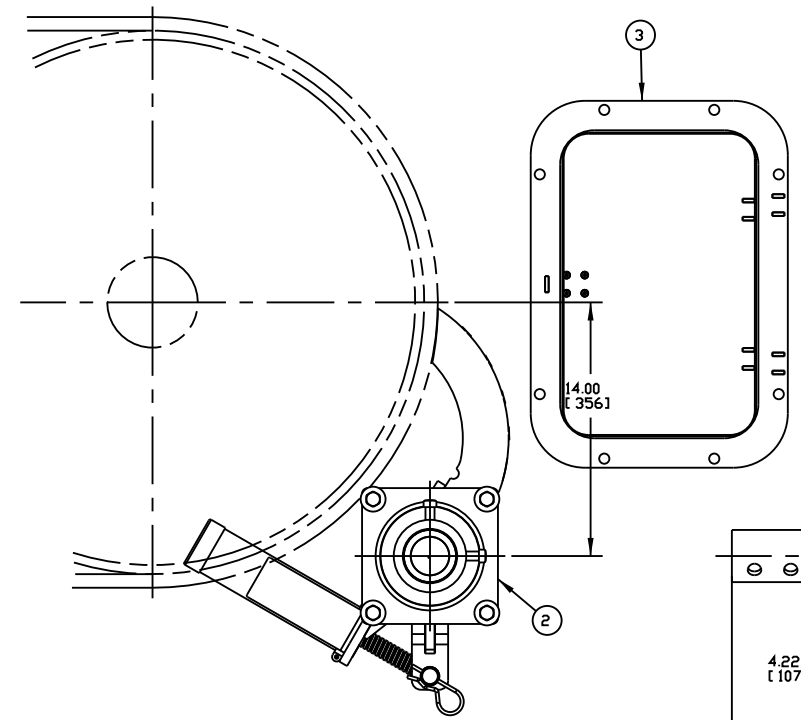
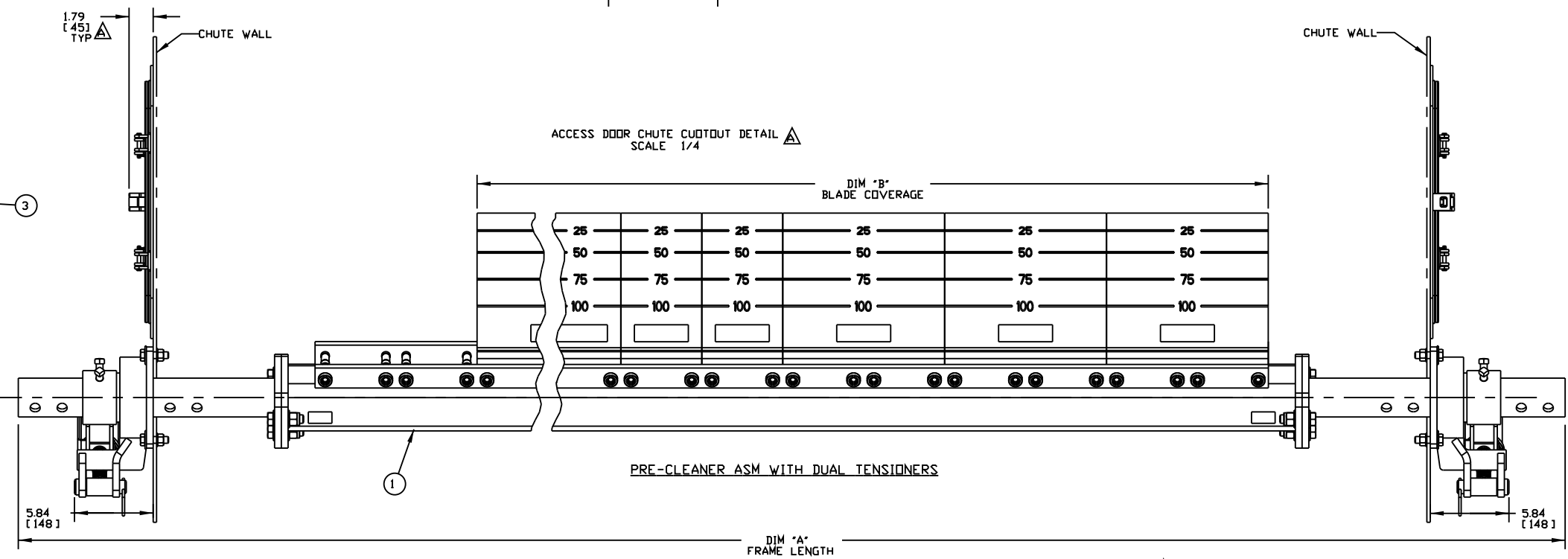
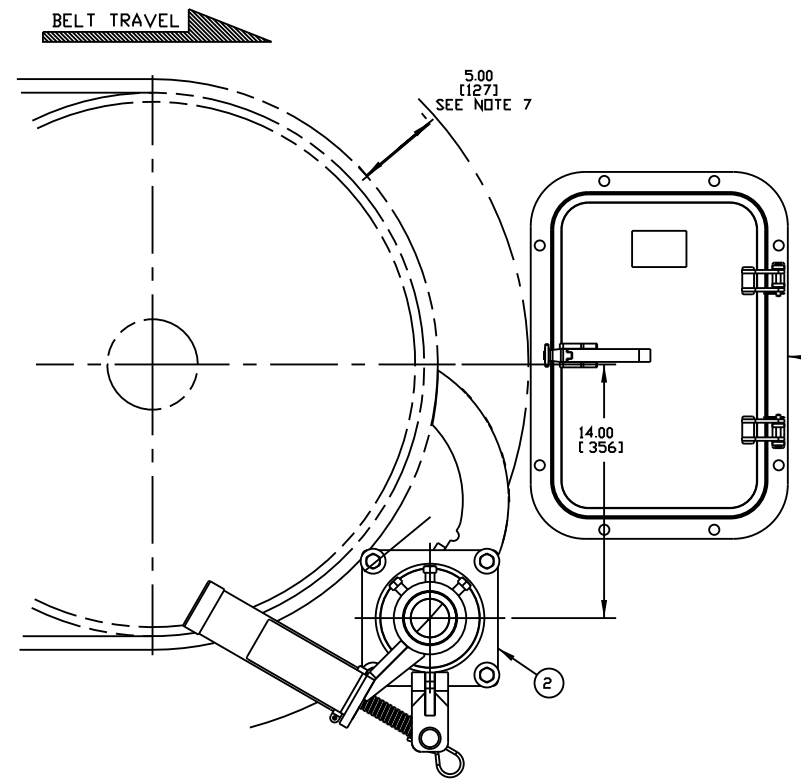

- NOTES:
- 1) ALL DIMENSIONS ARE GIVEN IN INCHES [MM].
  - 2) ALL DIMENSIONS ARE FOR REFERENCE ONLY.
  - 3) FOR EASY ACCESSIBILITY AND MAINTENANCE, MARTIN ENGINEERING RECOMMENDS BOLTING CLEANER TO EXISTING STRUCTURE WHEN APPLICABLE.
  - 4) CLEANER IS SHOWN IN RECOMMENDED WORKING POSITION.
  - 5) WHERE EXTREME OR UNUSUAL CONDITIONS EXIST, OR SPECIAL MAINFRAME LENGTHS ARE REQUIRED CONTACT MARIN ENGINEERING.
  - 6) REFER TO OPERATOR'S MANUALS M3542 & M3628 FOR COMPLETE INSTALLATION INSTRUCTIONS.
  - 7) CLEANER CAN BE LOCATED ANYWHERE ALONG THE ARC, AS LONG AS THE MAINFRAME IS OUT OF MATERIAL TRAJECTORY AND THE BLADE TIPS ARE BELOW THE HORIZONTAL CENTERLINE OF THE HEAD PULLEY.
  - 8) THE ZHD PRE-CLEANER BLADES ARE DESIGNED TO REMOVE HEAVY CARRYBACK ONLY. DO NOT OVERTENSION.
  - 9) ONE FULL TURN OF THE TENSIONING NUT ON THE SPRING TENSIONER IS EQUAL TO 20 [5].
  - 10) BLADE COVERAGE IS LESS THAN BELT WIDTH, DUE TO POSSIBLE MISTRACKING OR DAMAGED EDGES OF THE BELT.
  - 11) THE FIRST TWO XX'S IN THE P/N INDICATE THE BELT WIDTH. THE NEXT X INDICATES BLADE TYPE (NARROW & WIDE BLADES=BLANK, NARROW BLADES=V). THE NEXT XX INDICATES BELT COVERAGE (STANDARD BELT WIDTH -6"=BLANK, OR 6" INCREMENTS=XX). THE NEXT X INDICATES BLADE COLOR (ORANGE=BLANK, BROWN=B, GREEN=G, CLEAR=C, NAVY BLUE=N). THE NEXT X INDICATES TENSIONER (NO TENSIONER=BLANK, LINK TENSIONER=L, SPRING TENSIONER=S). THE NEXT X INDICATES BEARING TYPE (STANDARD DUTY BEARING=BLANK, HEAVY DUTY BRONZE METAL BEARING=M). THE LAST X INDICATES CABLE EXPANDER (NO CABLE CONNECTION KIT=BLANK, CABLE CONNECTION KIT=X). THE CABLE EXPANDER IS ONLY USED ON THE LINK TENSIONER.

P/N EXAMPLE:  
36287-24NBLMK = 24.00 BELT, ALL NARROW BLADES, STANDARD BELT COVERAGE, BROWN, BLANK, LINK, TENSIONER, BRONZE METAL BEARING, CABLE CONNECTION KIT. U.S. and Foreign Patents Pending. © 2007 Martin Engineering. All trademarks of Martin Engineering.

**MARTIN ENGINEERING** NEPONSET ILLINOIS USA

TITLE: ZHD # 800 PRE-CLEANER ASM WITH SPRING TENSIONER

DATE: 08/22/07

ENG: MJB

DATE: 08/22/07

APPROVED DM

DATE: 08/22/07

SCALE: 3/16

NO.	DESCRIPTION	ECN	DATE	BY
A	CHGD P/N FROM 34955-1218 TO CYA-1218 IN BEM/CHGD DIM FROM 2.78 TO 1.79/UPDATED ACCESS DOOR DIM'S	12961	04/06/10	MJB