

PART NO.	DIM 'A'	DIM 'B'	DIM 'C'	REPLACEMENT BLADE KIT	WEIGHT (LBS)
PLWVH-42XXT	24.56 [624]	48.00 [1219]	70.00 [1778]	38222-42XX	195
PLWVH-48XXT	27.56 [700]	54.00 [1372]	76.00 [1930]	38222-48XX	208
PLWVH-54XXT	30.56 [776]	60.00 [1524]	82.00 [2083]	38222-54XX	223
PLWVH-60XXT	33.56 [852]	66.00 [1676]	88.00 [2235]	38222-60XX	241
PLWVH-72XXT	39.56 [1005]	78.00 [1981]	100.00 [2540]	38222-72XX	283
PLWVH-84XXT	45.56 [1157]	90.00 [2286]	112.00 [2845]	38222-84XX	356
PLWVH-96XXT	51.56 [1310]	102.00 [2591]	124.00 [3150]	38222-96XX	408
PLWVH-120XXT	63.61 [1616]	126.00 [3201]	148.00 [3759]	38222-120XX	530

BLADE CHART	
ASSEMBLY P/N	COLOR
PLWVH-XXDRT	ORANGE
PLWVH-XXBRT	BROWN
PLWVH-XXGRT	GREEN

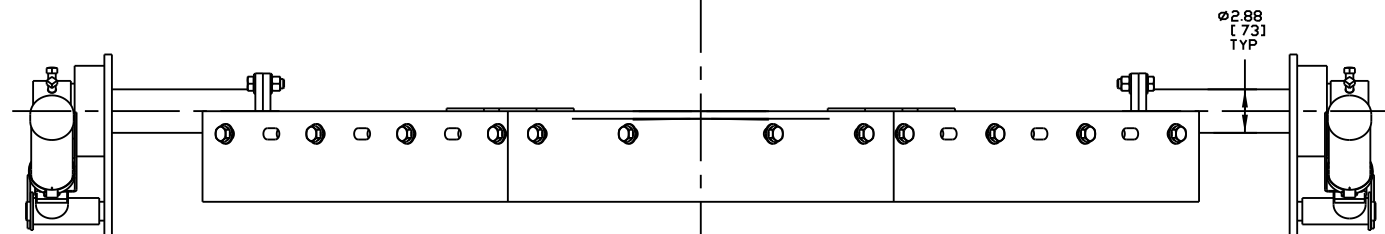
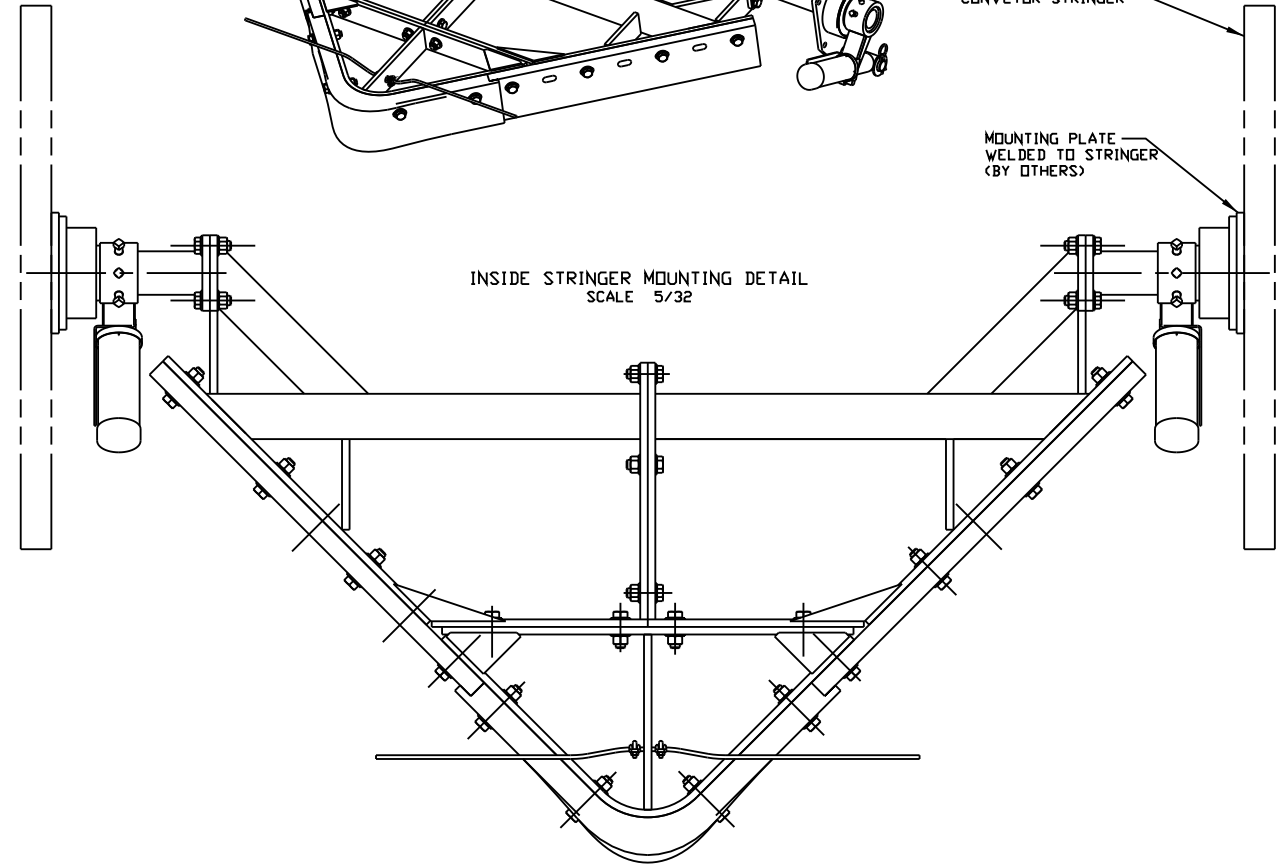
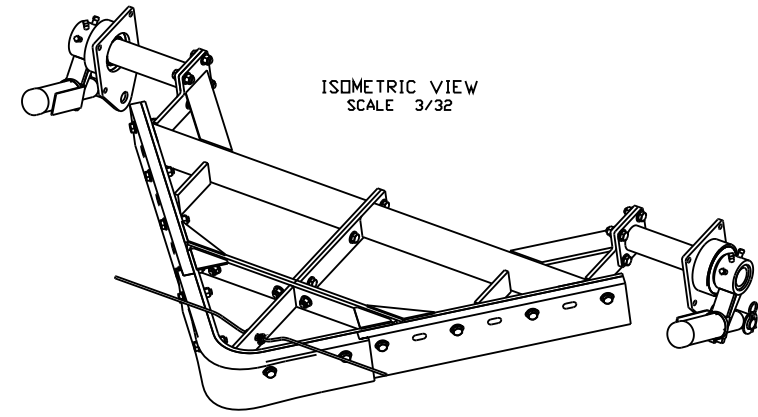
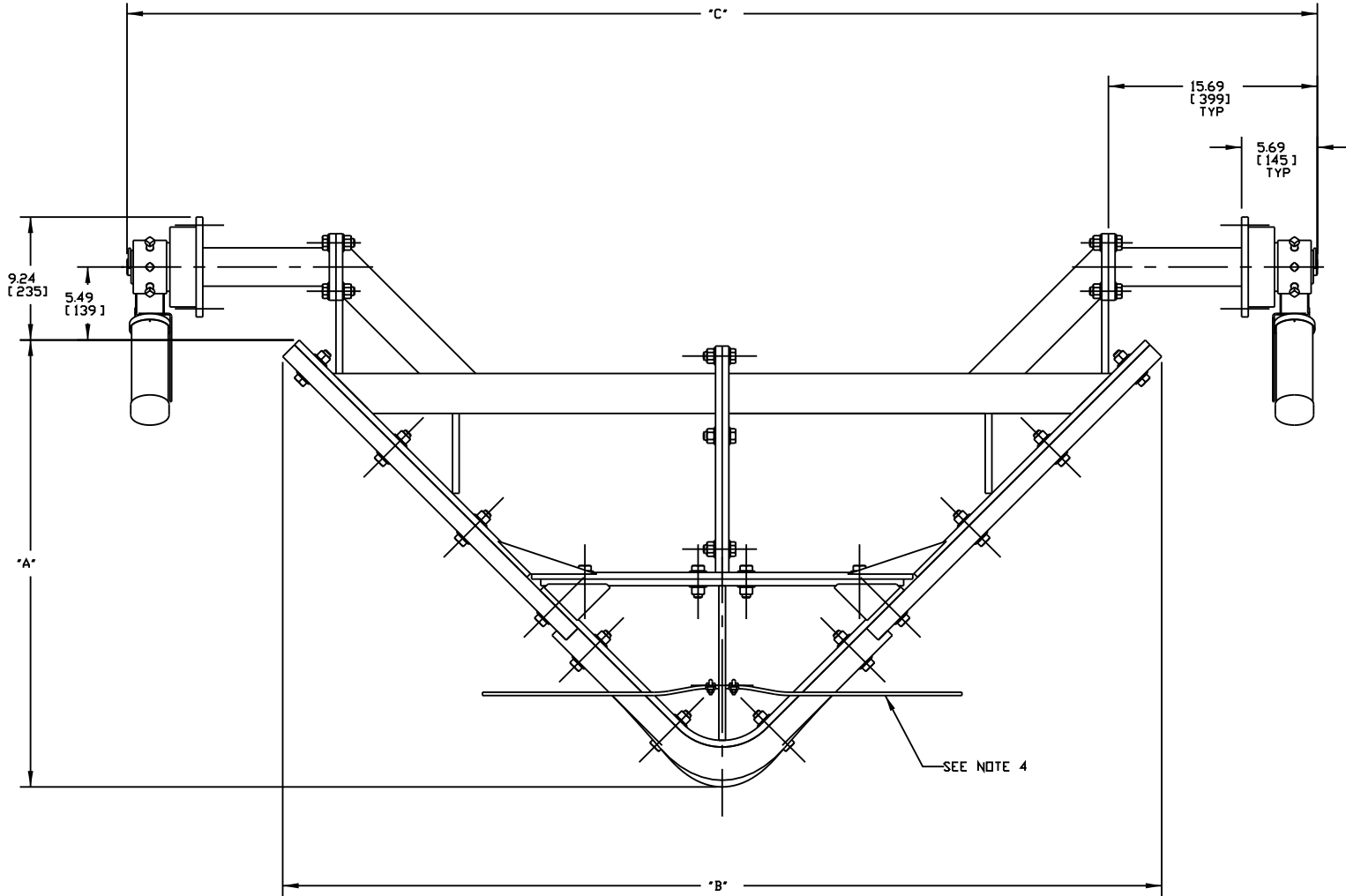

NOTES:

- 1) ALL DIMENSIONS ARE GIVEN IN INCHES (MM).
- 2) ALL DIMENSIONS ARE FOR REFERENCE ONLY.
- 3) IN THE P/N THE FIRST XX INDICATES BELT WIDTH, THE NEXT XX INDICATES BLADE COLOR/MATERIAL, THE LAST X INDICATES FRAME CONSTRUCTION/TENSIONER OPTION (P = PAINTED, S = STAINLESS STEEL, T = PAINTED STEEL SPRING TENSIONER).
- 4) SAFETY CABLE TO BE ATTACHED TO BOTH SIDES OF CONVEYOR STRUCTURE WITH SUPPLIED SHACKLES.
- 5) REFER TO OPERATORS MANUAL M3757 FOR V-PLOW INSTALLATION INSTRUCTIONS. REFER TO MANUAL M3512 FOR TENSIONER INSTRUCTIONS. TENSIONER WILL USE TENSIONER GAUGE WITH LABEL P/N 36055-P2 FOR V-PLOW BLADE TENSION SETTINGS (THIS IS THE SAME LABEL AS USED ON THE DUAL PRE-CLEANER BLADES).

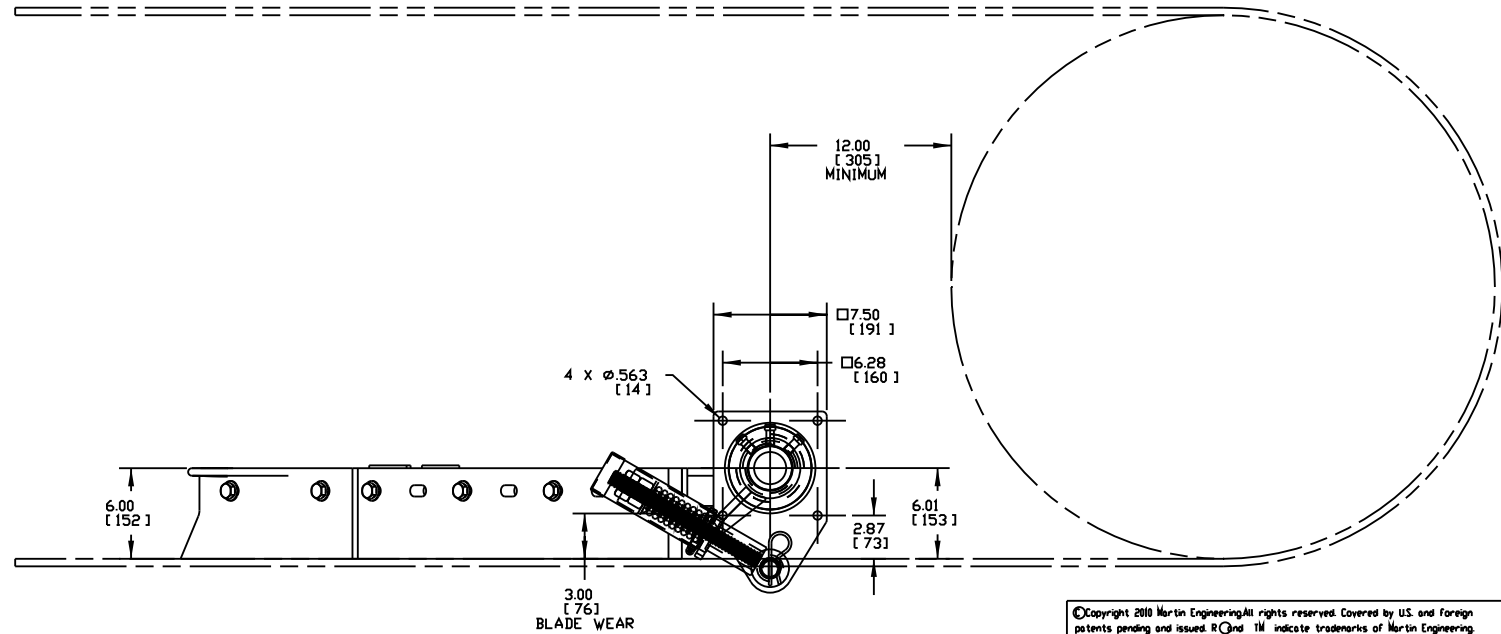

Copyright 2010 Martin Engineering. All rights reserved. Covered by U.S. and Foreign patents pending and issued. R and TM indicate trademarks of Martin Engineering.

MARTIN ENGINEERING
NEPONSET ILLINOIS USA

TITLE	MARTIN® HEAVY DUTY V-PLOW WITH TENSIONER	DRAWN	RND
DATE	01/19/10	CHECKED	
ENG.	JAP	APPROVED	DM
DATE	01/20/10	DATE	01/25/10
NO.	00000	SCALE	5/32

NO.	DESCRIPTION	ECN	DATE	BY
	REVISION			

SALES DRAWING S50052-T