

PART NUMBER	BELT WIDTH	DIMENSION "A" BLADE COVERAGE	DIMENSION "B" FRAME LENGTH
38556-18X10XXX	18.00 [400-500]	10.00 [254]	48.00 [1219]
38556-18X12XXX	18.00 [400-500]	12.00 [305]	48.00 [1219]
38556-18X16XXX	18.00 [400-500]	16.00 [406]	48.00 [1219]
38556-24X16XXX	24.00 [500-650]	16.00 [406]	54.00 [1372]
38556-24X18XXX	24.00 [500-650]	18.00 [457]	54.00 [1372]
38556-24X22XXX	24.00 [500-650]	22.00 [559]	54.00 [1372]
38556-30X22XXX	30.00 [650-800]	22.00 [559]	60.00 [1524]
38556-30X24XXX	30.00 [650-800]	24.00 [610]	60.00 [1524]
38556-30X28XXX	30.00 [650-800]	28.00 [711]	60.00 [1524]
38556-36X28XXX	36.00 [800-1000]	28.00 [711]	66.00 [1676]
38556-36X30XXX	36.00 [800-1000]	30.00 [762]	66.00 [1676]
38556-36X34XXX	36.00 [800-1000]	34.00 [864]	66.00 [1676]
38556-42X34XXX	42.00 [1000-1200]	34.00 [864]	72.00 [1829]
38556-42X36XXX	42.00 [1000-1200]	36.00 [914]	72.00 [1829]
38556-42X40XXX	42.00 [1000-1200]	40.00 [1016]	72.00 [1829]
38556-48X40XXX	48.00 [1200-1400]	40.00 [1016]	78.00 [1981]
38556-48X42XXX	48.00 [1200-1400]	42.00 [1067]	78.00 [1981]
38556-48X46XXX	48.00 [1200-1400]	46.00 [1168]	78.00 [1981]

MOUNTING LOCATION CHART	
DIM. "C"	
HEAD PULLEY DIAMETER	DIM. "D"
12.00 [305] THRU 15.00 [381]	4.00 [102]
16.00 [406] AND OVER	3.50 [89]

\* INCLUDES BELT AND LAGGING

- NOTES:
- ALL DIMENSIONS ARE GIVEN IN INCHES [MM] AND ARE FOR REFERENCE ONLY.
  - IN THE 38556-XXXXXXXXX PART NUMBER THE FIRST TWO XX'S INDICATE THE BELT WIDTH. THE THIRD X INDICATES A BLADE WITH (0) OR WITHOUT (1) SLITS. THE NEXT X INDICATES A BLADE WITH (0) OR WITHOUT (1) SEGMENTS. THE NEXT TWO XX'S INDICATE BLADE COVERAGE. THE NEXT TWO XX'S INDICATE BLADE COLOR. THE LAST X INDICATES IF A TENSIONER IS INCLUDED.
- EXAMPLES:  
 38556-361134BRT = 36" BELT WIDTH, 34" BROWN BLADE W/O SILTS AND SEGMENTS, WITH A TWIST TENSIONER.  
 38556-361028 = 36" BELT WIDTH, 28" ORANGE BLADE W/O SLITS AND WITH SEGMENTS.  
 38556-361128GRT = 36" BELT WIDTH, 28" GREEN BLADE W/O SLITS WITHOUT SEGMENTS, WITH A TWIST TENSIONER.
- CUT MAINFRAME TO LENGTH, WITH BLADE CENTERED ON THE BELT MEASURE HOW FAR THE MAINFRAME IS OUTSIDE THE CHUTE WALL AND ADD 1.63 [41] MINIMUM TO CUT OFF.
  - THE PRE-CLEANER BLADE IS DESIGNED FOR HEAD PULLEY'S WITH A MINIMUM EFFECTIVE DIAMETER OF 12.00 [305].
  - CLEANER IS SHOWN IN RECOMMENDED WORKING POSITION.
  - WHERE EXTREME OR UNUSUAL CONDITIONS EXIST, OR SPECIAL MAINFRAME LENGTHS ARE REQUIRED CONTACT MARIN ENGINEERING.
  - TWIST TENSIONER MAY BE BOLTED OR WELDED IN PLACE. MARTIN ENGINEERING RECOMMENDS BOLTING WHEN APPLICABLE FOR EASIER MAINTENANCE AND ACCESSIBILITY.
  - REFER TO OPERATOR'S MANUAL M3798 FOR COMPLETE INSTALLATION INSTRUCTIONS.
  - FOR BELT WIDTHS 54.00 [1400-1600] AND LARGER, MARTIN ENGINEERING RECOMMENDS USING A DUAL TWIST TENSIONER (P/N 38554-2). SEE S50068-D.
  - CLEANER CAN BE LOCATED ANYWHERE ALONG THE ARC, AS LONG AS THE MAINFRAME IS OUT OF MATERIAL TRAJECTORY AND THE BLADE TIPS ARE BELOW THE HORIZONTAL CENTERLINE OF THE HEAD PULLEY.
  - THE PD QC #1 PRE-CLEANER BLADES ARE DESIGNED TO REMOVE HEAVY CARRYBACK ONLY. DO NOT OVERTENSION.
  - FOR SEVERE APPLICATIONS WELD THE MAINFRAME ADAPTER DIRECTLY TO MAINFRAME.
  - BLADE COVERAGE IS LESS THAN BELT WIDTH, DUE TO POSSIBLE MISTRACKING OR DAMAGED EDGES OF THE BELT.

ITEM	QTY.	DESCRIPTION	PART NUMBER
1	1	MARTIN® PD QC™ #1 BLADE MAINFRAME ASM	38556-XXXXXXXX
2	1	MARTIN® TWIST™ TENSIONER ASM	38554
3	1	MARTIN® LOW PROFILE STL DOOR 9X12	CYA-0912

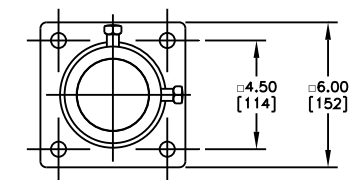
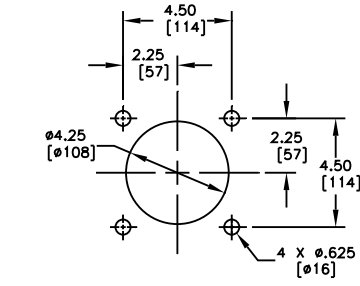
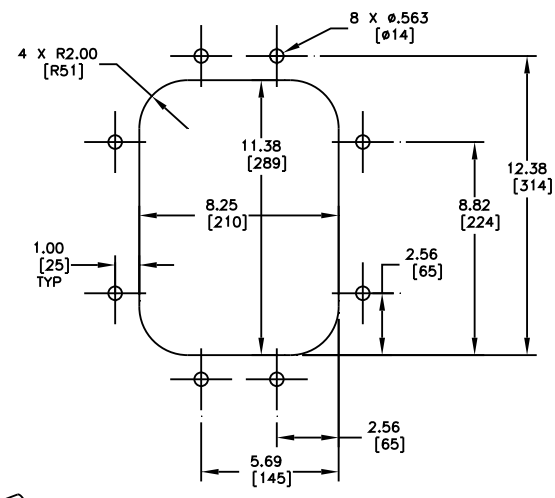

ASSEMBLY PART NO.	COLOR
38556-XXXXXX	ORANGE
38556-XXXXXBRX	BROWN
38556-XXXXXCLX	TAN
38556-XXXXXGRX	GREEN
38556-XXXXXNBX	NAVY BLUE

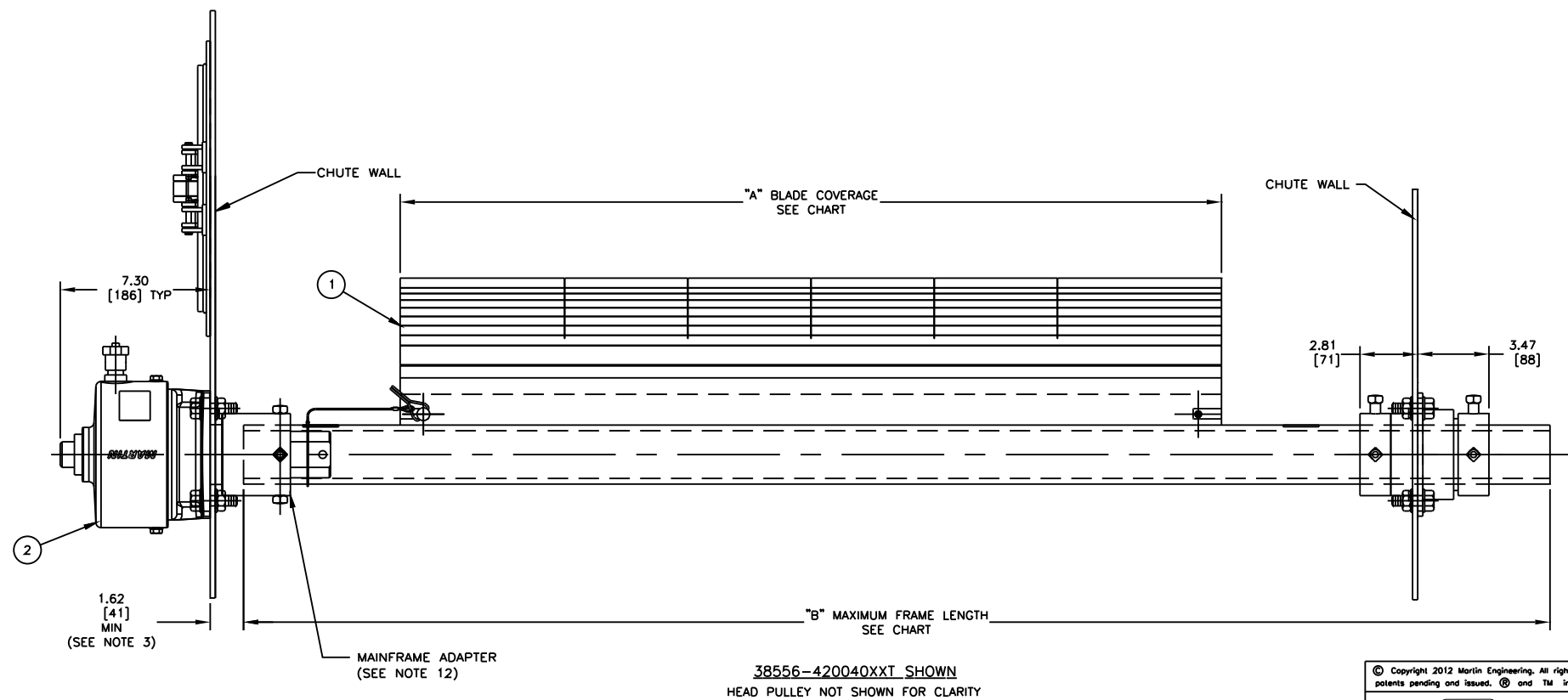
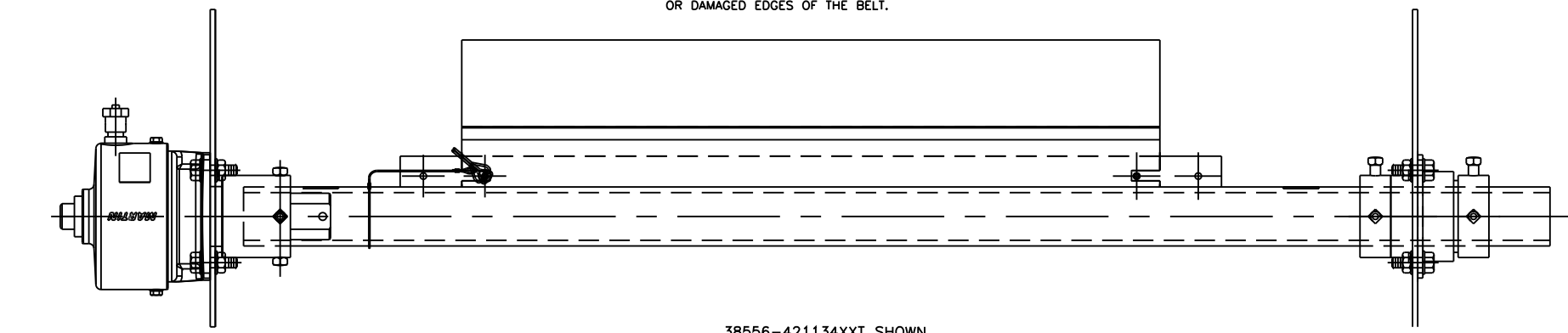
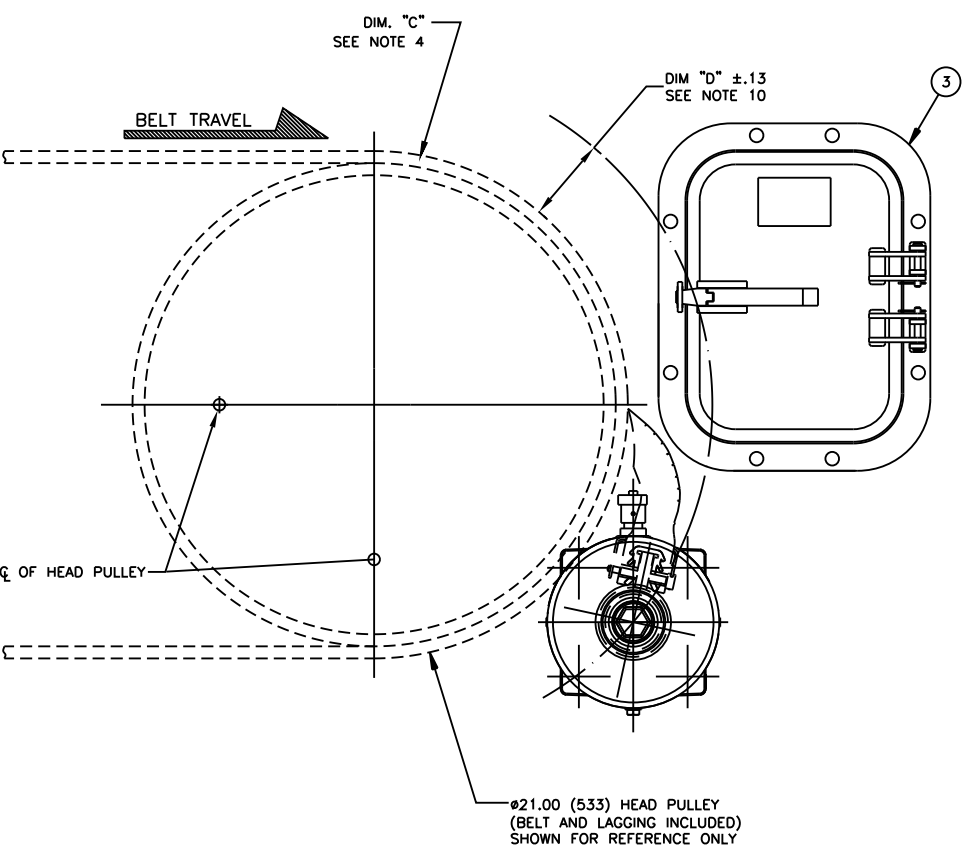
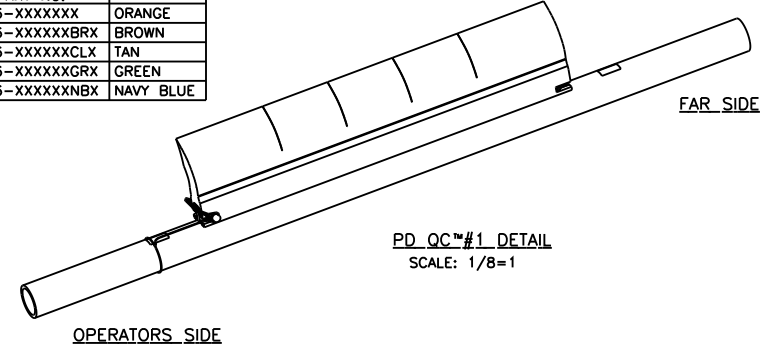

© Copyright 2012 Martin Engineering. All rights reserved. Covered by U.S. and foreign patents pending and issued. ® and TM indicate trademarks of Martin Engineering.

MARTIN ENGINEERING-USA  
NEPONSET, IL USA

TITLE: MARTIN® PERFORMANCE DUTY QC™ #1 ASM WITH TWIST™ TENSIONER ASM 9 X 12 STEEL DOOR

SALES DRAWING S50068-S

NO. DESCRIPTION ECN DATE BY

AutoCAD REVISION

PR11517

DRAWN RND DATE 08/13/09  
CHECKED DATE 08/19/09  
APPROVED DATE 08/19/09  
SCALE 1/4=1