

PART NUMBER	BELT WIDTH	DIMENSION "A" BLADE COVERAGE	DIMENSION "B" FRAME LENGTH
36898DA8XXA2XXX	108.00 [2600-2800]	102.00 [2591]	147.00 [3734]
36898DA8XXA6XXX	108.00 [2600-2800]	106.00 [2692]	147.00 [3734]
36898DC0XXB4XXX	120.00 [2800-3000]	114.00 [2896]	159.00 [4039]

ITEM	QTY.	DESCRIPTION	PART NUMBER
1	1	MARTIN® OC™ #1 HD DUAL BLD MNFRM ASM	36898DXXXXXXX
2	1	MARTIN® DUAL™ TWIST TENSIONER ASM	38850-2
3	2	MARTIN® LOW PROFILE STL DOOR 12X18	CYA-1218

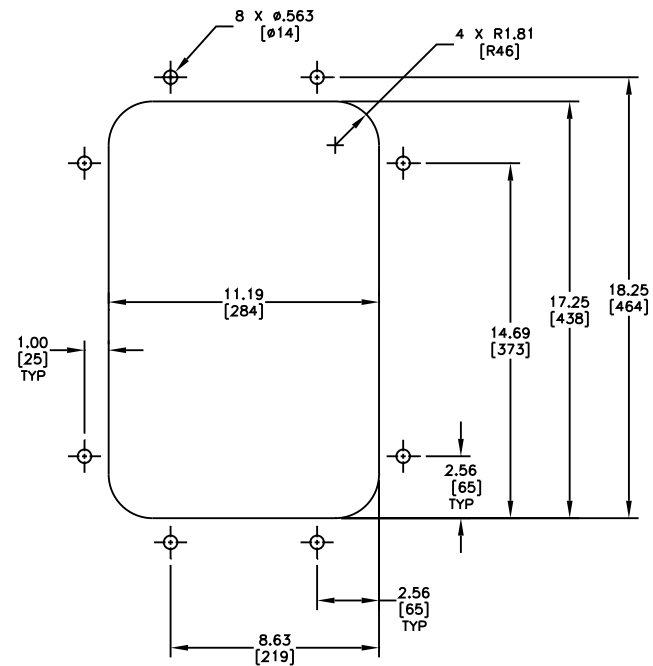

DOOR CUTOUT DETAIL FOR STEEL ACCESS DOOR
TYPICAL BOTH SIDES

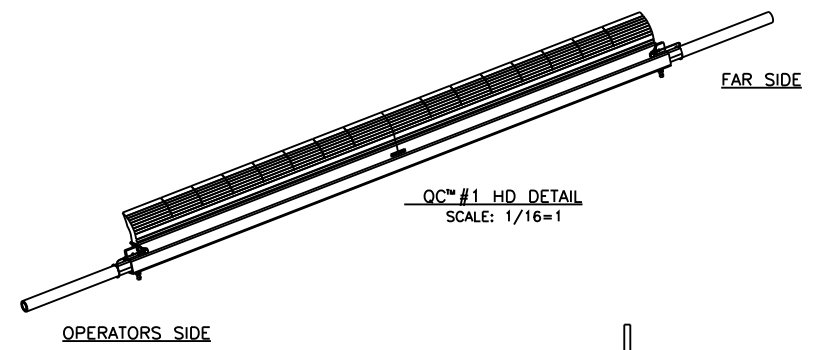

QC™ #1 HD DETAIL
SCALE: 1/16=1

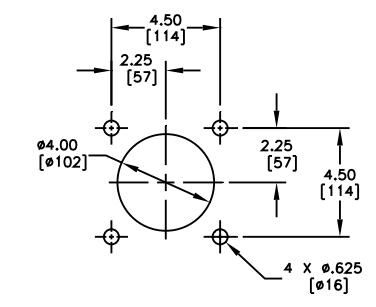

TENSIONER CHUTE WALL CUTOUT DETAIL
TYPICAL BOTH SIDES

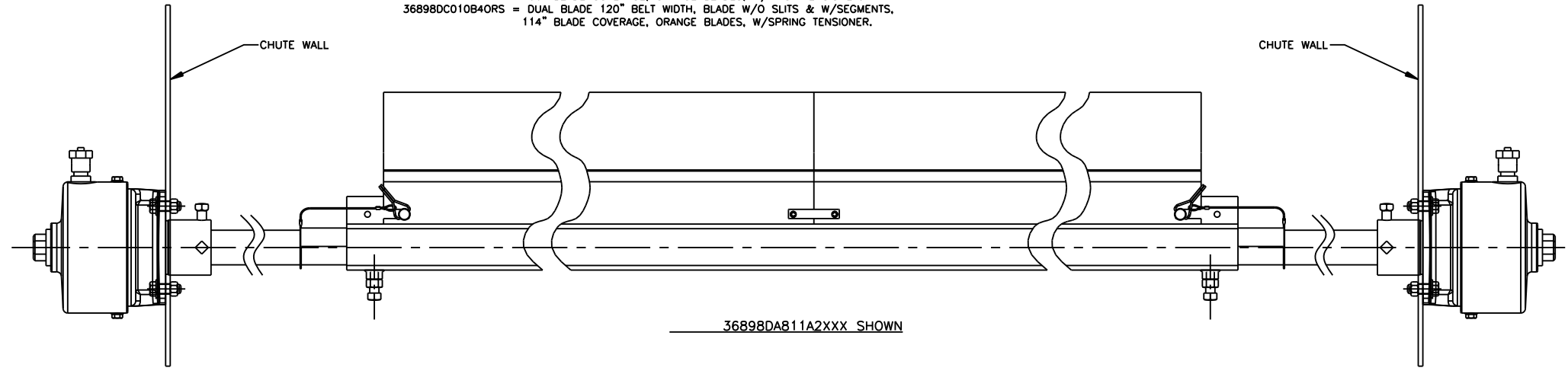

36898DA811A2XXX SHOWN

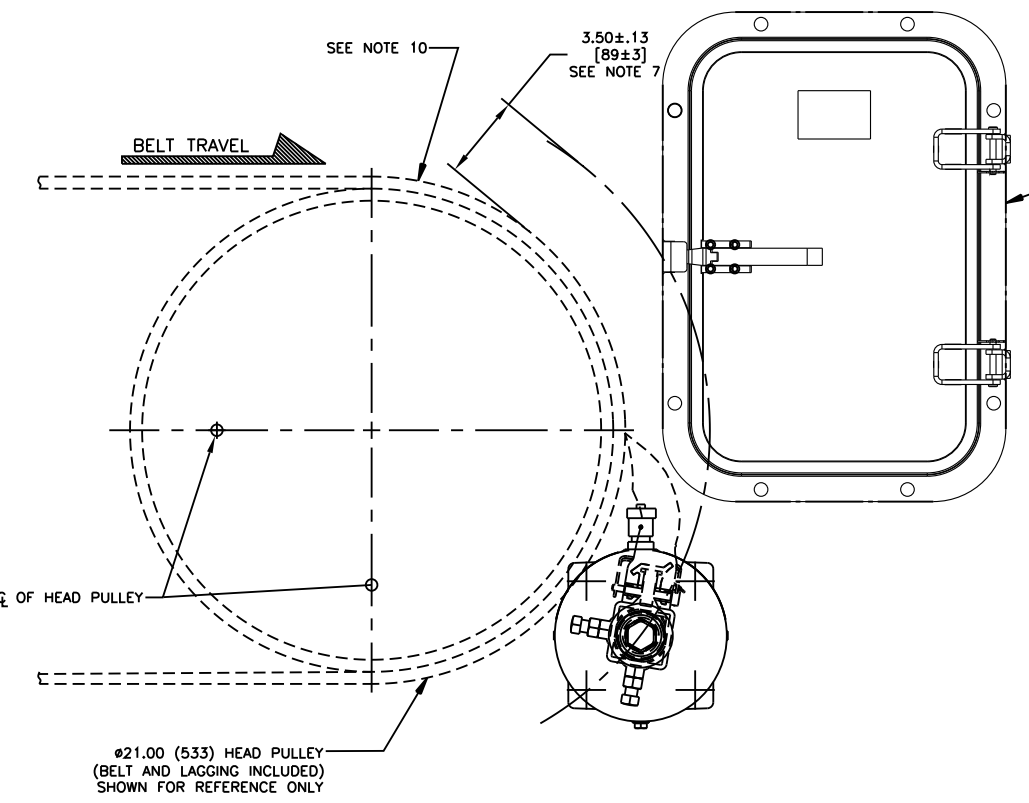

21.00 (533) HEAD PULLEY (BELT AND LAGGING INCLUDED) SHOWN FOR REFERENCE ONLY

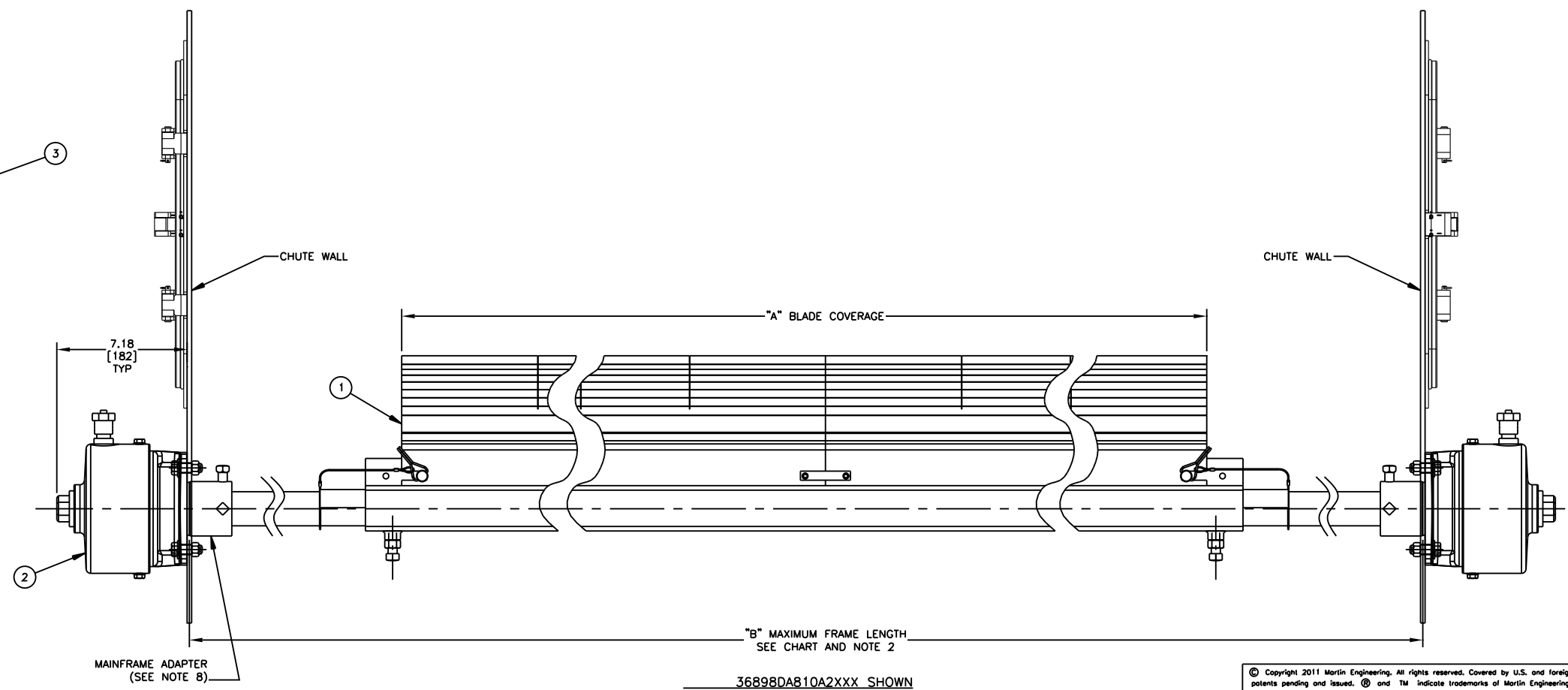

36898DA810A2XXX SHOWN
HEAD PULLEY NOT SHOWN FOR CLARITY

- NOTES:
- 1) ALL DIMENSIONS ARE GIVEN IN INCHES (MM) AND ARE FOR REFERENCE ONLY.
 - 2) FRAME IS ADJUSTABLE TO DESIRED LENGTH.
 - 3) THE "D" AFTER THE 5 DIGIT P/N INDICATES DOUBLE BLADE.
THE FIRST TWO XX'S INDICATE BELT WIDTH: A=10, B=11, C=12:
EXAMPLE: A8 = 108 ; B4 = 114 ; C0 = 120.
THE THIRD X INDICATES A BLADE WITH (0) OR WITHOUT (1) SLITS.
THE FOURTH X INDICATES A BLADE WITH (0) OR WITHOUT (1) SEGMENTS.
THE FIFTH AND SIXTH XX'S INDICATE BLADE COVERAGE: A=10, B=11, C=12:
EXAMPLE: A2 = 102 ; A6 = 106 ; B4 = 114 ; C0 = 120.
THE SEVENTH AND EIGHT XX'S INDICATE BLADE COLOR (SEE CHART).
THE NINTH X INDICATES IF A TENSIONER IS INCLUDED:
EXAMPLE (T=TWIST TENSIONER) AND (S=SPRING TENSIONER).

- ASSEMBLY EXAMPLES:
- 36898DA811A2NB = DUAL BLADE 108" BELT WIDTH, SOLID BLADE, 102" BLADE COVERAGE, NAVY BLUE BLADES, W/O TENSIONER.
 - 36898DA800A6ORT = DUAL BLADE 108" BELT WIDTH, BLADE W/SLITS & SEGMENTS, 106" BLADE COVERAGE, ORANGE BLADES, W/TWIST TENSIONER.
 - 36898DC010B4ORS = DUAL BLADE 120" BELT WIDTH, BLADE W/O SLITS & W/SEGMENTS, 114" BLADE COVERAGE, ORANGE BLADES, W/SPRING TENSIONER.

- NOTES (CONT'D):
- 4) WHERE EXTREME OR UNUSUAL CONDITIONS EXIST, OR SPECIAL MAINFRAME LENGTHS ARE REQUIRED, CONSULT MARTIN® ENGINEERING FOR ASSISTANCE.
 - 5) TWIST TENSIONER ASSEMBLY MAY BE BOLTED OR WELDED IN PLACE. MARTIN® ENGINEERING RECOMMENDS BOLTING WHEN APPLICABLE FOR EASIER MAINTENANCE AND ACCESSIBILITY. IF WELDING IS REQUIRED USE TWIST TENSIONER ASSEMBLY P/N 38850-2A.
 - 6) REFER TO OPERATOR'S MANUALS (M3296 AND M3618) FOR INSTALLATION INSTRUCTIONS.
 - 7) MARTIN® ENGINEERING RECOMMENDS THE CLEANER BE LOCATED SO THAT THE BLADE TIP IS AT OR SLIGHTLY BELOW HORIZONTAL CENTERLINE OF HEAD PULLEY. CLEANER IS SHOWN BELOW IN RECOMMENDED WORKING POSITION.
 - 8) FOR SEVERE APPLICATIONS WELD MAINFRAME ADAPTER DIRECTLY TO MAINFRAME.
 - 9) THE OC #1 HD PRE-CLEANER BLADE IS DESIGNED TO REMOVE INITIAL CARRYBACK ONLY. DO NOT OVERTENSION!
 - 10) THE OC #1 HD PRE-CLEANER BLADE IS DESIGNED FOR HEAD PULLEYS WITH A MINIMUM EFFECTIVE DIAMETER OF 12.00 (305).

© Copyright 2011 Martin Engineering. All rights reserved. Covered by U.S. and foreign patents pending and issued. ® and TM indicate trademarks of Martin Engineering.

MARTIN ENGINEERING - USA
NEPONSET, IL USA

TITLE	DATE	DRAWN	CHECKED
MARTIN® OC™ #1 HD DUAL BLD ASM W/DUAL TWIST™ TENSIONER 12 X 18 STEEL ACCESS DOORS	04/05/11	JAH	JAH
SALES DRAWING			
NO.	DESCRIPTION	ECN	DATE
AutoCAD	REVISION		

NO.	DESCRIPTION	ECN	DATE	BY
A	CHGD QTY. OF P/N CYA-1218 FROM 1 TO 2 / ADDED NOTE "TYPICAL BOTH SIDES" TO DOOR CUTOUT DETAIL	13863	02/26/14	JAH

S50090-DUAL
SCALE 1/4=1