

ITEM	QTY.	DESCRIPTION	PART NUMBER
1	1	MARTIN® QC #1 HD MAX ASSEMBLY	SEE CHART
2	1	MARTIN® HD MAX SPRING TENSIONER	38947
3	1	MARTIN® LOW PROFILE ACCESS DOOR	CYA-1218

PART NO.	BELT WIDTH	DIM "A" MAX FRAME LENGTH	DIM "B" BLADE COVERAGE
38926-24XX12XXX	24.00 [500-650]	72.00 [1829]	12.00 [305]
38926-24XX18XXX	24.00 [500-650]	72.00 [1829]	18.00 [457]
38926-30XX18XXX	30.00 [650-800]	78.00 [1981]	18.00 [457]
38926-30XX24XXX	30.00 [650-800]	78.00 [1981]	24.00 [610]
38926-36XX24XXX	36.00 [800-1000]	84.00 [2134]	24.00 [610]
38926-36XX30XXX	36.00 [800-1000]	84.00 [2134]	30.00 [762]
38926-42XX30XXX	42.00 [1000-1200]	90.00 [2286]	30.00 [762]
38926-42XX36XXX	42.00 [1000-1200]	90.00 [2286]	36.00 [914]
38926-48XX36XXX	48.00 [1200-1400]	96.00 [2438]	36.00 [914]

ASSEMBLY PART NO.	COLOR
38926-XXXXXX	ORANGE
38926-XXXXXXBRX	BROWN
38926-XXXXXXCLX	TAN
38926-XXXXXXGRX	GREEN
38926-XXXXXXNBX	NAVY BLUE
38926-XXXXXXYLX	YELLOW

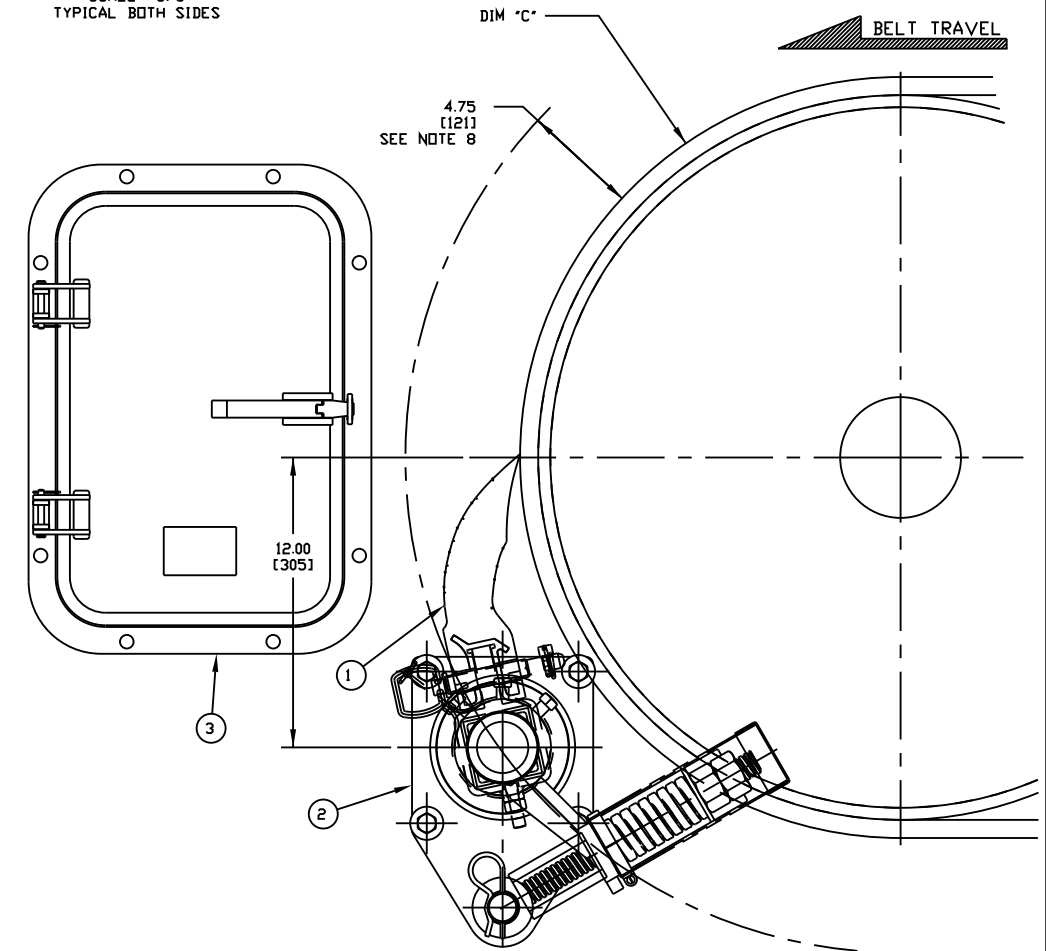
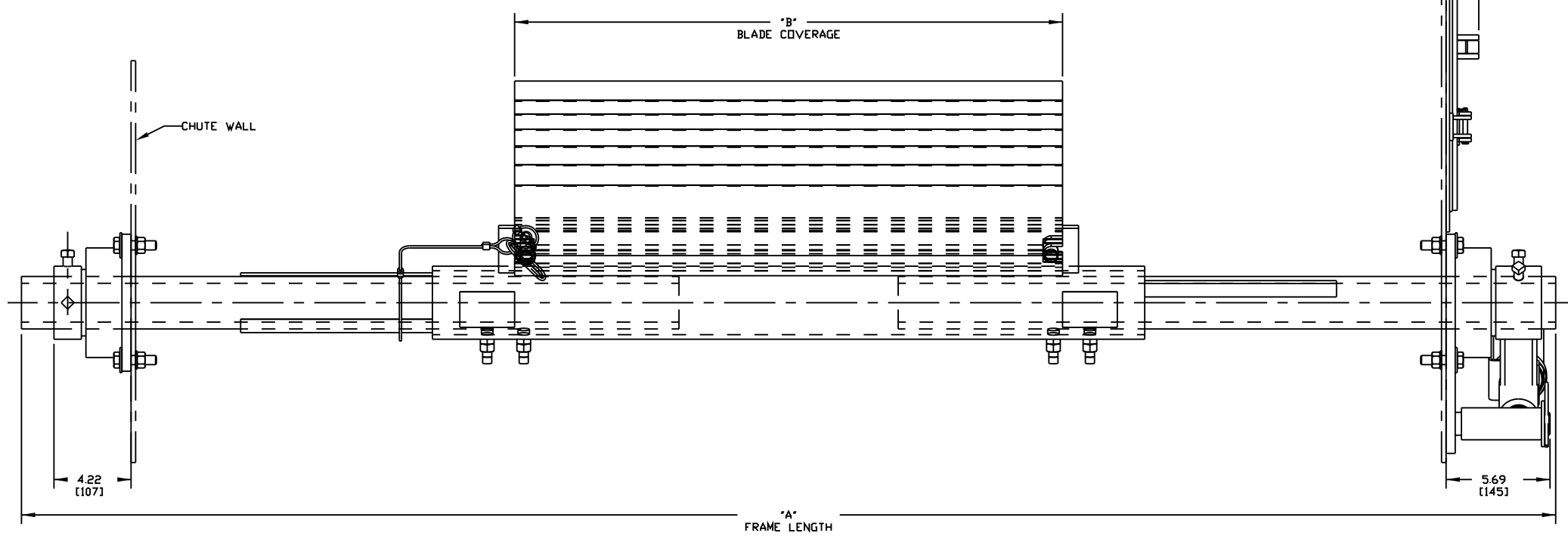
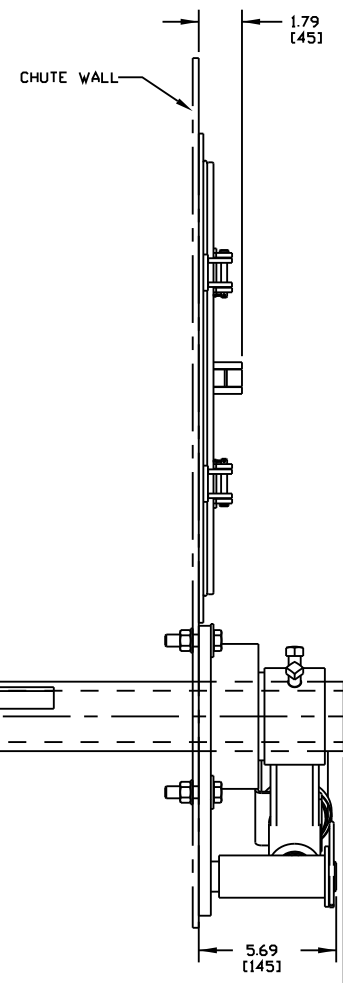
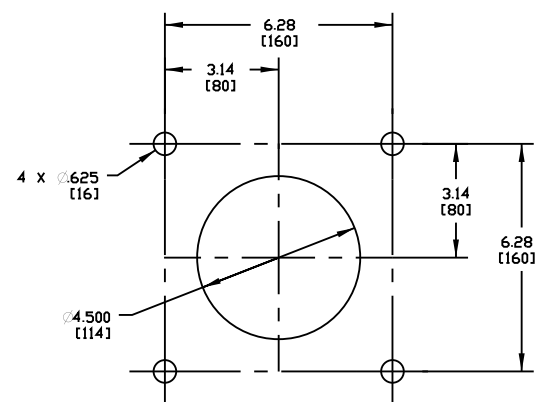
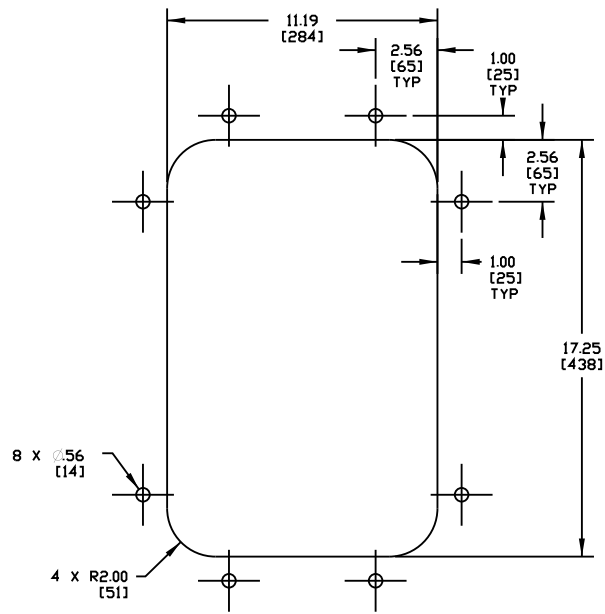

- NOTES:
- 1) ALL DIMENSIONS ARE GIVEN IN INCHES [MM].
 - 2) ALL DIMENSIONS ARE FOR REFERENCE ONLY.
 - 3) FOR EASY ACCESSIBILITY AND MAINTENANCE, MARTIN ENGINEERING RECOMMENDS BOLTING CLEANER TO EXISTING STRUCTURE WHEN APPLICABLE.
 - 4) CLEANER IS SHOWN IN RECOMMENDED WORKING POSITION.
 - 5) WHERE EXTREME OR UNUSUAL CONDITIONS EXIST, OR SPECIAL MAINFRAME LENGTHS ARE REQUIRED CONTACT MARTIN ENGINEERING.
 - 6) REFER TO OPERATOR MANUALS M3886, & M3127 FOR COMPLETE INSTALLATION INSTRUCTIONS.
 - 7) FOR BELT WIDTHS 48.00 [1200-1400] AND BIGGER, MARTIN ENGINEERING RECOMMENDS USING A DUAL HD MAX SPRING ARM TENSIONER.
 - 8) CLEANER CAN BE LOCATED ANYWHERE ALONG THE ARC, AS LONG AS THE MAINFRAME IS OUT OF MATERIAL TRAJECTORY AND THE BLADE TIPS ARE BELOW THE HORIZONTAL CENTERLINE OF THE HEAD PULLEY.
 - 9) THE HD MAX QC #1 PRE-CLEANER BLADES ARE DESIGNED TO REMOVE HEAVY CARRYBACK ONLY. DO NOT OVERTENSION.
 - 10) ONE FULL TURN OF THE TENSIONING NUT ON THE SPRING TENSIONER IS EQUAL TO 20 [5].
 - 11) BLADE COVERAGE IS LESS THAN BELT WIDTH, DUE TO POSSIBLE MISTRACKING OR DAMAGED EDGES OF THE BELT.
 - 12) THE FIRST TWO XX'S OF THE CLEANER PART NUMBER INDICATE BELT WIDTH. THE THIRD X INDICATES SOLID (S) OR SLIT (L). THE FOURTH X INDICATES SOLID/SLIT (S/L). THE NEXT TWO XX'S INDICATE BLADE WIDTH, THE NEXT TWO XX'S INDICATE BLADE COLOR/MATERIAL. THE LAST X INDICATES IF A TENSIONER (T) IS INCLUDED. EXAMPLE: 38926-361130BR (36.00 BELT WIDTH, 30.00 SOLID, BROWN BLADE).

©Copyright 2011 Martin Engineering. All rights reserved. Covered by U.S. and Foreign patents pending and issued. R and TM indicate trademarks of Martin Engineering.

MARTIN ENGINEERING NEPONSET ILLINOIS USA

TITLE	MARTIN® QC #1 HD MAX PRE-CLEANER WITH XHD SPRING TENSIONER AND 12X18 ACCESS DOOR	DRAWN	RND
DATE	10/25/11	CHECKED	
ENG.	MJB	DATE	01/05/12
APPROVED	DM	DATE	04/26/12
SCALE	1/4		

SALES DRAWING
PR12177 S50095-S

NO.	DESCRIPTION	ECN	DATE	BY
	REVISION			